

SYSTEM DYNAMICS MODEL

FOR STUDYING THE IMPACT OF TECH-PROGRESS ON ECONOMICS

Yukui Hu and Suling Jia

Beijing Institute of Aeronautics and Astronautics

ABSTRACT

The consumption of resources and the environmental pollution caused by the discharge of waste materials and waste heat occur as useful products are being turned out in the social-economic activities. Based on the concept of entropy, the paper deals with the impact of tech-progress on every link of this process. This is the major mechanism for the impact of the tech-progress on economics.

One of the characteristics of the modern society is an interaction of the three closely related factors, namely, technological progress, economic growth and social progress, of which science and technology, serving as a productive force, is the most active one. Without it, research on both the revitalization of economics and the issues arising from the social reform could not be done.

The impact of tech-progress on economics is a rather complicated problem. In order to reveal the essence of it, a "System Dynamics Model for Studying the Impact of Tech-Progress on Economics" was constructed by applying the methods of system dynamics. The model presents the dynamic varying process of the tech-progress--national economy system in 1980--2010 and offers some proposals on the basis of simulating a number of policies.

The tech-progress may affect economics in many aspects. There are six factors being considered in the model, that is, the macroeconomics, the investment space, the tech-progress, the overexploited resources, the environmental pollution and microeconomics. The cause and effect relationship of the model is shown in figure 1, in which the positive feedback loop is composed of the net output value indicating the macroeconomics, the investment space, the tech-progress and microeconomics. This is a major mechanism for the impact of tech-progress on the economic growth. The development of the macroeconomics boosts the advancement of technology by providing

it with necessary financial resources. Basically speaking, the development of tech-progress depends on the revitalization of the macroeconomics and in turn the tech-progress gives a stimulus to the macroeconomics. This is a process for the tech-progress to be transformed into the productive capability. All accumulated achievements in scientific research and improved techniques should be regarded as a kind of potential tech-progress before they are applied to the socialized macro-production. To turn the potential technology into the benefit-yielding technology calls for certain conditions, such as social demand, investment, etc. Even if these conditions are given, it also takes time for the potential technology to fulfill the transformation. Here, the "social demand" stands for the demand for developing new technology evoked by the increasingly rapid improvement of the people's material and cultural life. It also includes the demand of enterprises and workers for adopting new techniques to facilitate the production process. Likewise, the "investment" here also has two connotations: investment by the government for developing new technology (investment in research development) and investment by the enterprises for technical transformation and introduction (investment in technological development). The time required for the potential technology to be transformed into both the benefit-yielding technology is an intricate parameter, having something to do with people's concept of value, their management level, their insight as well as their pioneering spirit.

As the tech-progress is chiefly embodied by the revitalizing of the microeconomics, the model gives a description of two major micro-elements: the progress of enterprises and the progress of farmer households. The level of these two elements directly affects the net output value of the macroeconomics. The microeconomic activities do create the macroeconomics, but they are also a cause for the environmental pollution and over-exploitation of resources. The two side-effects from the microeconomic activities form a negative feedback loop. The more prosperous the microeconomics is, the more serious the environmental pollution becomes and the more severe the consumption of resources will be. The other way around, both the aggregation of the environmental pollution and the over-exploitation of the resources will frustrate the microeconomic activities by limiting their capabilities. The way to tackle this problem is to resort to the tech-progress. The development of tech-progress will result in a lessening of environmental pollution and a rational

utilization of resources, which will add two more positive feedback loops to the system as a whole.

As it is known to all, gross national income is composed of industry, agriculture, commerce, building industry and communications and transportation industry. Investment comprises two parts: investment in research development and investment in technological development. The fulfillment of the two kinds of investment is dependent on enterprises and farmer households as well as macro-financial resources.

The key elements to bring about the advancement of technology are research development, technological potential, technological demand, and technological progress. Research development, if defined, includes three kinds of research activities, that is, scientific research, exploring development and application research, each possessing its own technological potential. Tech-demand reflects the needs of the society for certain technology. The technical subjects adopted in the model include microelectronics, bio-engineering, new materials, energy engineering and transportation and communications. Between technological potential and all sorts engineering technology is a relation matrix describing the pressure exerted on the demand for new technology by the tech-potential accumulated from various development activities. Besides, the development level of enterprises and farmer households is also a source of influence on the technological demand. It makes relevant progress in technology in demand and with necessary investment. Thus, through research activities, investment in research development aids the formation of the tech-potential and further, the formation of demand (pressure) for developing new technology. The pressure from the demand along with the investment in technological development constitutes the conditions for the tech-progress to take place. However, it takes time to enable the tech-progress to yield benefits in industry. This process of prolonging exists in the tech-progress, being regarded as its dynamic varying process.

The five kinds of tech-progress are weighted to act on the progress of enterprises and farmer households. The macroeconomics hinges on three factors: the progress of enterprises, the progress of farmer households and the ecological losses and damages (environmental pollution and over-exploitation of resources). Proceeding from the

concept of ecologic-economy, here we tried to show that the evaluation of the gross national income should not only rest on the output value, but also on the ecological losses and damages. For instance, how many pollutants are discharged for each 100 RMB worth of net output value? How many resources does it cost? And how much money these sacrifices would be worth? In a work, when applying ourselves into the economic growth, we'll have to pay attention to the economic results. We should weigh the pros and cons from an objective, long-term point of view. This, we might say, is the right purpose of making this mode.

Figure 2 is the rough flow chart of the "System Dynamics Model for Studying the Impact of Tech-Progress on Economics", in which only level variables and major auxiliary variables are presented. As for the variables of current velocity that control the level, a sketch is made so as to make it easy to display the basic structure of the model.

The model involves the following seven sub-models:

1. Sub-Model for the Macroeconomics

It consists of five level variables from the output values of capital construction, transportation, commerce, industry and agriculture describing the net output value of the macroeconomics. The GNP standard is adopted in calculating the output values given in the model. Both the output-value-generating valve and the material-consuming valve are controlled by the tech-progress. And the generating valve is simultaneously controlled by the progress of enterprises, the progress of farmer house holds and the ecological losses and damages.

2. Sub-Model for Tech-Progress

The essential factors promoting the tech-progress are research development activities. The level variables adopted here are scientific research, exploring development and application research. The generating valves of the three level variables are controlled by the progress of enterprises and the progress of farmer households as well as the investment, and these level variables are disappearing at a certain rate. The level variables derived from the research development are the tech-potential--- the resultant levels corresponding to the three research activities above. The

factor controlling the tech-potential valve can be found in the relevant research activities, and this sort of level is terminating at a certain rate as well.

The demand for technology is also a level variable, whose generating valve is initiated by the activities involving three research developments along with the levels of the progress of enterprises and the progress of farmer households. The interacting relations between them are displayed by the relevant multipliers.

Described as a level variable, the tech-progress is defined in accordance with the technical categories corresponding to the tech-demand. The various generating valves for tech-progress are respectively controlled by the investment and the demand coming from the relevant categories of technology. A prolonging device (deferrer) is contrived between the generating valves and the levels of tech-progress so as to manifest the stagnation in time, the period of which begins with the investment and ends with the tech-progress coming into being.

3. Sub-Model for the Progress of Enterprises

One of the most active factors in the mechanism for the impact of tech-progress on economics is the development level of enterprises (hereafter referred to as "the progress of enterprises"). The so-called progress of enterprises here does not specifically mean the progress made by a certain enterprise but the progress of enterprises in terms of macrostructure. In the model, it means the progress of enterprises evaluated by taking a comprehensive view of the situation throughout the country. Attached to the model, this sub-model for the progress of enterprises is composed of the newly-built enterprise, the mature enterprise, the outdated enterprise and the progress of enterprises, which are streamlined to describe the development level of the enterprises. The factors affecting the level of the progress of enterprises include the tech-progress and the state of enterprises themselves. For the latter, such aspects as the quality of workers, the quality and number of technical staff members, the quality of managerial personnel and the fixed assets may turn out to be very complicated. In the model, an experiment is conducted on the increasing process for the newly-built enterprises with reference to the growth of investment in the fixed assets in China. The annual growth rate is 17.8 per cent. As

newly-built enterprises are expanding too fast with a slow increase of technical capability (10 per cent), there emerge a great number of newly-built enterprises in 1970's---1980's and the number of mature enterprises tend to decline. When the investment in newly-built enterprises is reduced to 4 per cent and the growth rate of technical capability is enhanced to 15 per cent, the curve representing the newly-built enterprise moves up at first, and begins to come down year by year after 1980 whereas the curve representing the mature enterprise markedly goes up and keeps a stable trend of increase from the second half of 1970's to the year of 2000 figure 3.

The current situation of the outdated enterprises is also an imperative problem in our country. The experiment conducted in the model indicates that any increase of investment in technical transformation would mean allocating more funds to the out-of-date enterprises or introducing equipment from foreign countries or increasing investment in other capital construction. This will result in an obvious reduction of the number of the enterprises that need to be transformed. But because the capability of these enterprises to materialize the technology is insufficient and the technology can not come into effect for a long period of time, an increase of the number of newly-built enterprises is seen in the model. The percentage of the mature enterprises depends merely upon the enterprises' vitality and technical capability. To bring in new equipment for enterprises but fail to help them improve their technical absorbing ability to deal with the equipment at the same time is just like keeping this part of the introduced equipment in the newly-built enterprises forever. So the key to carry out the technical transformation of the out-of-date enterprises lies in the enhancement of technical capability, namely, the research capacity and the development capacity.

4. Sub-Model for the Progress of Farmer Households

This model consists of small farmer households, midium-sized farmer households engaged in the specialized production, advanced specialized households and the progress of the farmer households. The small farmer households are the little families formed with the natural growth of the rural population. With the development of the specialization in the rural production, the small farmer households will have to undergo changes. Some of them have already

turned into medium-sized specialized households and will further develop into the advanced specialized households. Meanwhile, a large number of surplus labour forces produced by small farmer households will constantly be entering into the "third industry" in the rural areas. This, to a great extent, will further strengthen the specialization campaign in the countryside and in turn stimulate the further transforming of the small farmer households. Here, the condition for the transformation is the service space. The tech-progress plays a major role in providing this space. In the experiment, the varying performances of the three kinds of farmer households are rendered under the respectively different state of the tech-progress. It happens that when an increase of tech-progress is urged at an average rate of 10 per cent, 15 per cent and 18 per cent, the curve moves towards indicating the markedly reduction of the number of the small farmer households while the curves representing medium-sized and advanced specialized households move towards indicating a gradual increase of their numbers until reaching the top value. With the development of the tech-progress, the top value is likely to appear ahead of schedule.

5. Sub-Model for Land Sources

Land is another striking problem in respect of the surface resources. The sub-model for land sources presented here is designed in the light of the general trend that the green land and arable have continuously been occupied. It comprises the green land, the land for industrial use, the land for agricultural use, the land for governmental use, the land for building's use and the forest land. Both the generating and disappearing (terminating) velocities of all sorts of land are affected by the tech-progress and the government policy. The result of the experiment in the model shows that the green land and arable land have roughly the same tendency of reduction. This phenomenon shall be attributed to a drastically fast increase in the land occupied for the governmental use, the building's use and the industrial use. It necessary to have the use of land strictly planned and limited. But it is almost impossible to completely control its decrease, especially at a time when the arable-land-decreasing-trend can be hardly altered, though tech-progress and necessary administrative measures may help diminish the decreasing speed.

However we hold that the enormous potential of our land sources does not lie in its absolute area but in the improvement of its quality so as to bring the land efficiency into full play. Therefore it is imperative to develop a scientific way for farming, to improve the quality of land, to make an effective use of water sources and develop fine breeding. In China, agriculture still has a great potential to tap. This is also an important aspect for the impact of tech-progress on economics.

6. Sub-Model for Energy Sources and Environmental Pollution

The other sub-model in the section of resources is the model describing the energy sources and pollutants discharged by the necessary energy generated by energy sources. As energy sources can be derived from a wide range of resources, there must be a variety of contaminated materials thereupon. In the model, however, only coal and petroleum are selected.

The coal flow is made up of the reserves, the inventory, the coal for electrical use, the coal for industrial and civilian use as well as such variables as CO, NO_x, SO and smoke dust. Petroleum flow is made up of the deposits, the inventory, the petroleum for electrical use, the petroleum for motor vehicle's use and the petroleum for other purposes. It also consists of the variables discharged by energy-generating process, such as, CO, NO_x and SO. The tech-progress plays a part in the course of the two flow movements. In fact, the model has attempted to seek a policy, under which, financial resources permitted, the tech-progress works to its full extent so that the discharge of harmful materials can be minimized.

7. Sub-Model for Water

Water, as one of the component parts in the organism of resources and environment, is made up of the variables of water for industrial use, the waste water from industry, the water for agricultural use, the water for civilian use and the sewage from such a use and the water for township enterprise's use. The industrial waste water couldn't be disposed properly without the scientific and technological progress.

Above are the simple compositions of the seven sub-models. The purpose of this designing is to describe such a macro-system

stating that the state of macroeconomics is dependent on such factors as the level of micro-production, the degree of pollution and the level of discovery and utilization of resources. And the level of the micro-performances is decided by the tech-progress. In that way, macro-policy-making is confronted with this alternative as to how many financial resources would be considered as appropriate for the investment in science and technology in view of a long-term interest. The process of the so-called impact of the tech-progress on economics is just developed in the above micro-processes. And the macro-policy-making will determine the degree and effect of each micro-process.

-----THE END-----

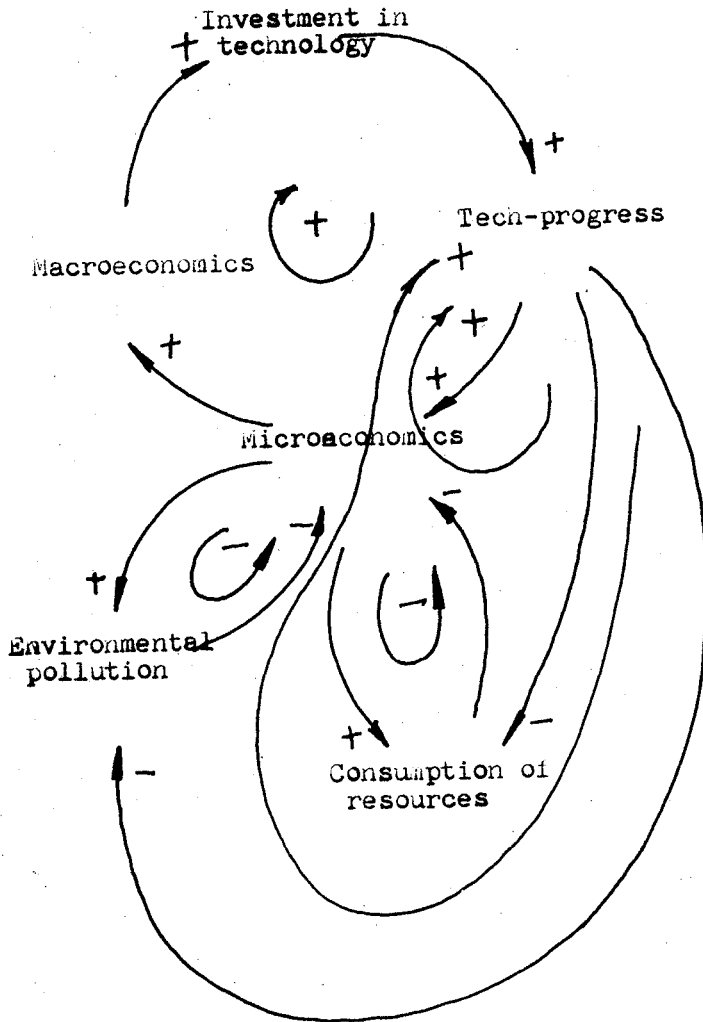

Fig. 1

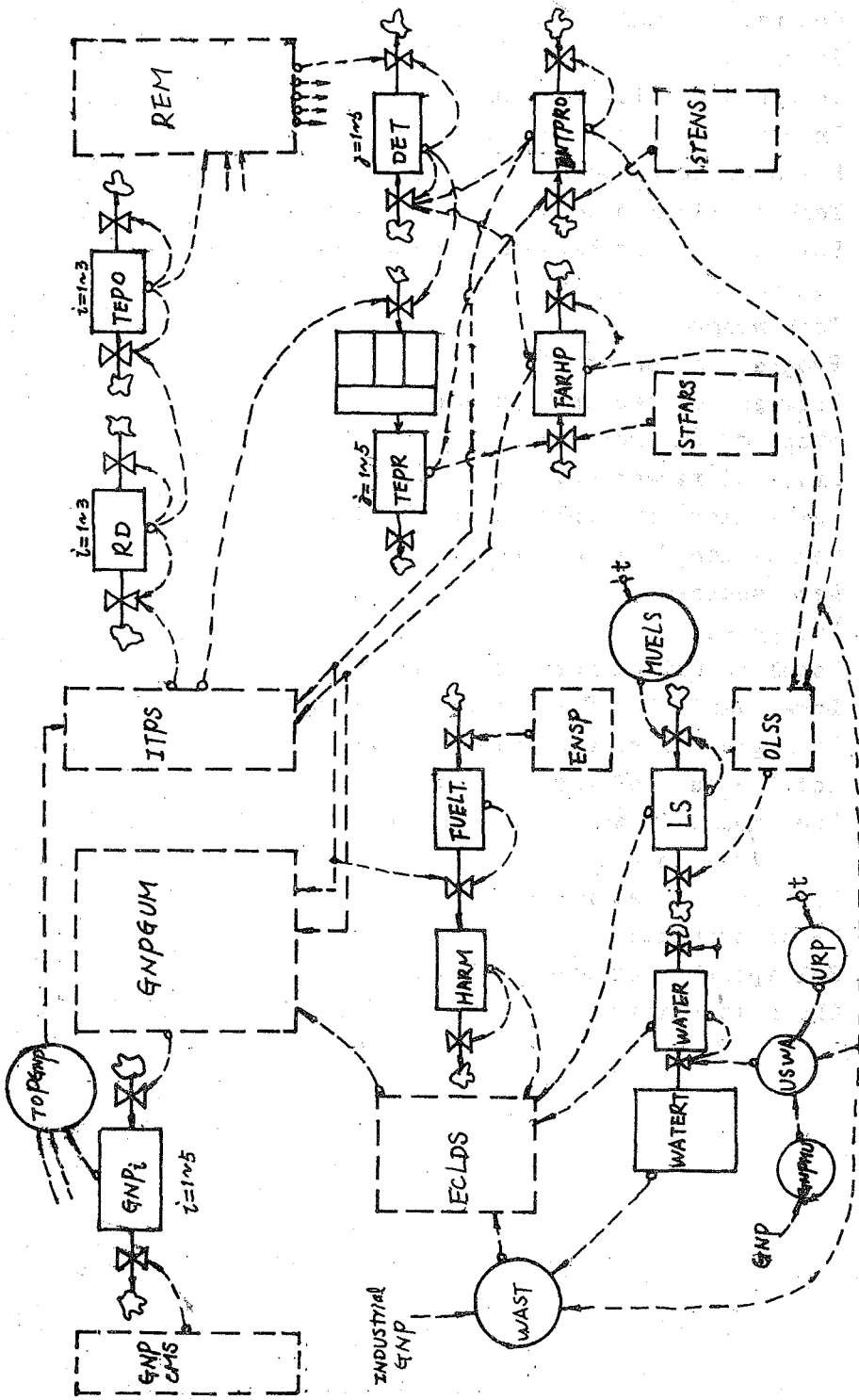

Fig. 2

GNPCMS	Consumption multiplier space
TOTGNP	Total GNP
GNPGUM	Generating multiplier matrix
ITPS	Investment in tech-progress space
RD	Research development
TEPO	Technological potential
REM	Relation matrix between tech-potential and tech-progress
DET	Demand for technology
TEPR	Tech-progress
ENTPRO	Progress of enterprises
FARHP	Progress of farmer households
STENS	State of Enterprises space
STFARB	State of farmer households space
MUELS	Multiplier for exploitation of land sources
OLSS	Occupation of land sources space
LS	Land sources
ENSP	Energy space
FUELT	Total amount of fuel for combustion
HARM	Level variables for harmful materials
ECLDS	Ecological loss and damage space
WAST	Total amount of waste water
WATERT	The amount of water for industrial, agricultural and civilian use
WATER	Richness of water sources
URP	Urban population
USWA	Multipliers for use of water
GNPMU	GNP multipliers

