

A System Dynamics Model for Economic Planning in Sarawak

Brian Dangerfield

Centre for OR & Applied Statistics

University of Salford

SALFORD M5 4WT

U.K.

44-161-295-5315 (T)

44-161-295-2130 (F)

Email: b.c.dangerfield@salford.ac.uk

Abstract

This paper describes the outcome of a research project undertaken for the government of the State of Sarawak in E. Malaysia. A system dynamics model was constructed so as to inform the State's future economic and social planning to 2020. Positive engagement with State government officials at the highest levels was a feature of the successful completion of the work. A flexible policy evaluation tool for use in their macro-economic planning is now available to be used by those officers who were exposed to several training sessions in system dynamics modelling.

Introduction

Nothing manifests complexity more than an economic system. Here we observe myriad interactions between physical production, employment, finances and government policy. In addition there are likely exogenous effects which can impinge on the system and are driven by international market movements, political upheavals or even terrorism.

The development of computers in the 1950's and 60's together with the systematic collection of national economic data led to a pursuit of economic planning based upon models which attempted to make sense of this data with a view to forecasting the future of key economic variables. The emergence of econometrics as an adjunct to economic science was born. Nowadays hardly any developed nations lack an econometric model. If the central government itself have not built one, then one or more university or private research institutions will have. However, these models have been criticised (Black, 1982).

The reliance on econometric models for macro-economic management is common, but it is not necessarily the best methodology for exploring, evaluating and reflecting on policy options. Meadows and Robinson (1985) review a range of methodologies and include system dynamics amongst them. They make a cogent case for the usefulness of system dynamics in national economic planning.

The application described below is one rooted in a developing economy. Some of the material described has been made available already whilst the research was a work-in-progress (Dangerfield, 2005). Examples of systems-based approaches to developing

economies are available in the broader operational research literature (see for instance Parikh, 1986 and Rebelo, 1986) but it is only relatively recently that SD has begun to acquire a prominence in development planning (Barney, 2003; Chen and Jan, 2005; Morgan, 2005). The Sarawak project is important in the sense that it is another contribution to empirical macro-economic modelling using SD. Moreover, the project has exposed (and hopefully convinced) government officials as to the merits of SD as a methodology in this sphere of application.

Determination of model purpose

The determination of a purpose for an SD model is well grounded in the literature. Here a brief had been agreed: to provide the State with a tool to aid their future economic planning. But this is too broad an objective. A specific purpose needed to be defined and a period of time was spent after the commencement of the research in reviewing the various strands of thinking in the state government and, in particular, reading the key speeches of ministers to see what was preoccupying them. There would be no benefit derived from the creation of some grand planning tool if it was not consonant with the interests and ambitions of the primary stakeholders.

A proposal was eventually tabled and agreement secured to develop the model with the following purpose:

How and over what time-scale can the State of Sarawak best manage the transition from a production-based economy (p-economy) to a knowledge-based economy (k-economy) and thereby improve international competitiveness?

There had been concerns raised in ministerial speeches that the resource-based economy, which had served Sarawak well in over two decades of development, was coming under pressure from other industrialising nations, in particular China. To secure further international competitiveness the state needed to develop more high-tech industry with higher value-added products and services: in short there was a desire to shift towards a k-economy, implying the emergence of a quaternary sector.

A high level map for the model

The diagram shown in figure 1 sets out, in as economical a way as possible, the overall structure of the model designed to address the issue above.

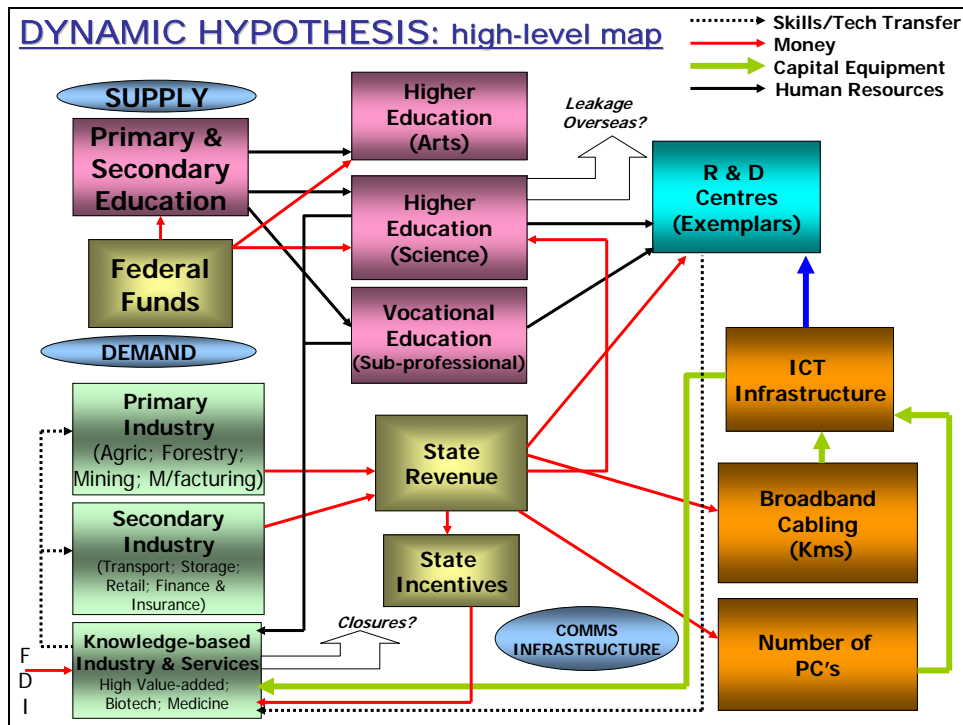

Figure.1. The high-level map used to guide the developing model

There are three main aspects to be handled and an appropriate triangulation of these components is key to managing a successful transition to a knowledge economy:

- The supply of suitably trained human capital and entrepreneurs.

This is the output from the education sector shown towards the top left of the diagram. Clearly the primary and secondary education sector provides the output of students some portion of which will progress to higher education. Both arts and science specialisms are represented and there are indications that the balance here does not currently favour the enhancement of science skills which underpin the k-economy. The current graduate output ratio is weighted heavily in favour of arts courses. However, over recent years this imbalance has been tackled from the point in School career where students choose a future pathway: Form Four (F4) level.

The vocational sector is also represented since development of a k-economy is augmented by an important group of sub-professionals (e.g. technicians) who have a crucial supporting role to play.

Funding for most education in Sarawak is provided by the federal government. However, and primarily in an effort to develop the science base, the State Government have funded certain private university developments. State funding in this manner can play an important part in expediting the flow of suitably qualified individuals who will stimulate the development of a k-economy.

- The demand side of a k-economy: those knowledge-based industries and services which are emerging (in some cases as development of primary and secondary industry) to form an ever-increasing component of the economy.

The sectors towards the bottom left of Figure 1 are split into Primary (the production and resource based sector also called the p-economy); Secondary (the service sectors such as tourism, finance and professional services); and the knowledge-based sector (the k-economy or quaternary sector).

The evolution of the quaternary sector is propelled by a mixture of foreign direct investment and State funding. But this alone is insufficient, for a flow of skilled human capital is essential as is the quality of the ICT infrastructure which must have attained an appropriate level of sophistication.

The growing emergency of a quaternary sector can appear to consume resources which might otherwise have been directed to primary and secondary industry. But it must be stressed that, contemporaneously, development of the k-economy will mean direct skill and technology transfer benefits to the existing base of primary and secondary industry. It is impossible to ignore the bedrock components of the p-economy which can, in turn, be enhanced as part of overall economic development. The sectors are currently the main providers of state revenue (via taxation and employment) and are likely to remain so.

- The state of the ICT infrastructure, which in some senses mediates the evolution of the drivers of supply and demand.

The quality of the ICT infrastructure can be fairly easily measured by appropriate metrics. Two such examples are the length of the broadband data highway within Sarawak and the estimated number of PC's installed.

Again, it would be expected that the State government revenue would, in large measure, underpin the enhancement of these metrics, although foreign direct investment cannot be ruled out.

An ICT infrastructure of reasonable sophistication will also be necessary in order to allow the development of a number of Research and Development (R&D) Centres of Excellence, as indicated in Figure 1. The initiation of such projects is suggested in order that best practice k-economy activities can be showcased and publicised. These centres will make it clear that the State government is strongly promulgating the development of the quaternary sector through provision of funds to allow these start-up operations to proceed.

Development of a k-economy would be constrained if the supply of science graduates and suitable sub-professional k-workers are not forthcoming, which is why emphasis has been placed upon coincident (or even prior) educational changes. Initial staffing of such centres may be a problem but it is possible that, with sufficiently attractive remuneration packages, qualified Sarawak expatriates would be tempted to return.

The proposed R & D centres can be seen as crucial catalysts in the stimulation of the quaternary sector and they will offer a primary supply of people with the necessary skill sets to enthrone the creation and development of knowledge-based industry and services.

The dynamic flows to be considered are:

- Skills and technology transfer
- Money and all forms of financial resource
- Capital Equipment
- Human Resources (Capital)

Within the industry sectors (particularly the Primary Sector) there are also dynamic flows of goods, material and orders.

Description of some important model sectors

The Population Sector

Within this sector the age-based population structure of Sarawak is represented. This is an important input to modelling sustainable economic activity within the State. The flow diagram for this sector is shown below as Figure 2. The main summary variables are available e.g. population age 15 and under; population 15 to 64 (taken to be the working population); population 65 and over; and the total population. The dependency ratio is also computed. This is an important demographic ratio which expresses the non-working subset of the population (the young and the old) as a percentage of the total population. The higher is this value the greater the pressure on the State's working population to support the strata that is not economically active.

Extensive census data is collected for this sector usually on a ten-year cycle and thus the formulation of the model for population flows is straightforward since the parameters are readily available. However, estimates have to be made for years between census dates and we have employed the 1995 estimates to initialise the population in each age group.

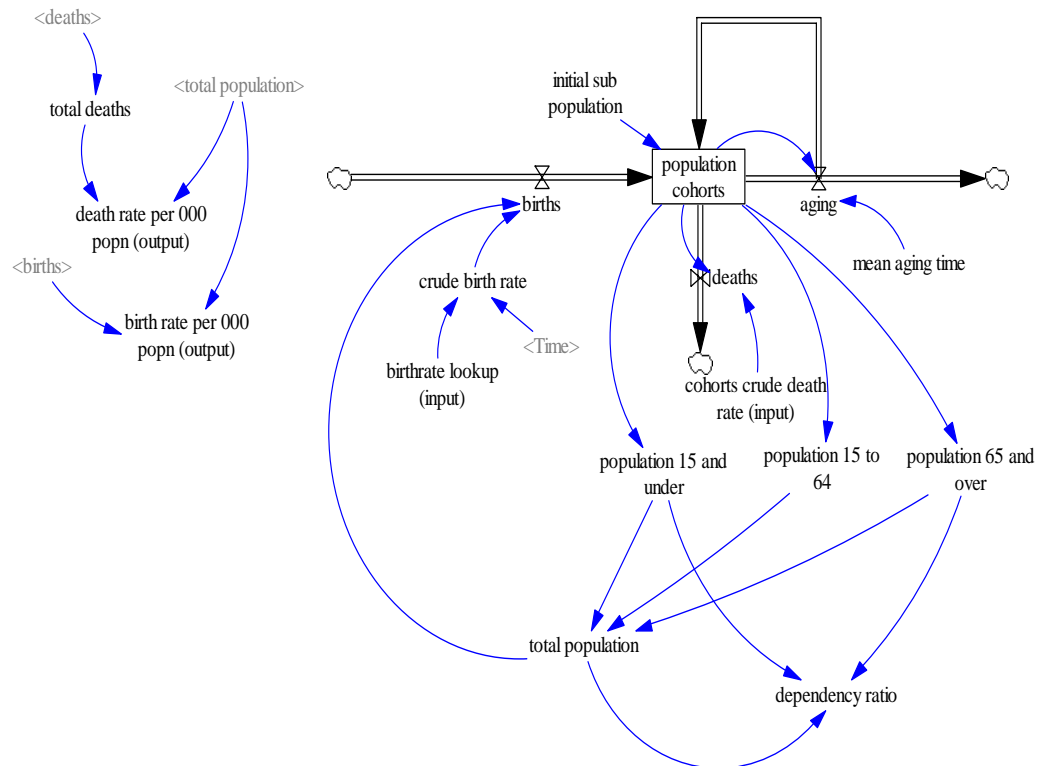

Figure. 2. The Population sector sub model

The population sub-model is presented succinctly as a flow of births which adds to population cohorts which are, in turn, depleted by deaths. A critical feature is that the population is stratified into 15 age cohorts from 0-4, 5-9, 10-14 and so on up to 65-69 and finally 70+.

Although not shown in figure 2, the age bands are modelled separately along an ageing chain. The Vensim software allows such a decomposition through its array facility. Although any age group can be extracted (e.g. for plotting or to use elsewhere in the model), it is usual to concentrate on the important broad age ranges and the total population, as described above.

The data which provides the parameters for this sub-model is collected in an EXCEL spreadsheet. In general, many of the model's parameters are stored in this way because Vensim allows the extraction of both parameter values and historical time series from EXCEL spreadsheets and external data (text) files.

There are separate crude death rates for each age band (estimated from the census data) and separate initial population values for each also. By initial population we mean the initial number of persons in that age band at the commencement of the simulation in 1995.

A distinction is made between *input* and *output* for crude birth and death rates. *Input* values for crude death rates are those estimated from the data, whilst the *input* crude birth rates were provided directly as data up to the most recent year for which figures are available or are derived from a linear interpolation process out into the future to

2020. *Output* values are calculated in the model as part of the simulation and are presented as aggregates over the entire population. In part they act as a check on the data entered but also provide a useful overall metric for consideration. For instance the crude death rate in the older age bands might be expected to reduce over calendar time as a result of improved medical care. Currently, these *inputs* are held constant. This possibility, if implemented, should be reflected in the *output* value for the overall crude death rate per thousand ('000s) of the population.

Education & Human Capital Sectors

Progression to a k-economy will take some time but will be propelled by the twin thrusts of investment in people and a communications infrastructure. In respect of obtaining a suitably qualified labour force we need to place the centre of gravity of the model around the production of higher-educated and technically-qualified human capital. These developments underpin a suitably skilled workforce and, in view of the importance attached to this, a workforce sector has been added (see section below).

The education sector is considered here and has been split as between Primary and Secondary education (Primary 1 – Primary 6 and Form 1 – Form 5 respectively) on the one hand and Tertiary education on the other. The extent and importance of these model sectors means that they cover two separate views. Firstly the model of Primary and Secondary education is described and is represented by Figure 3.

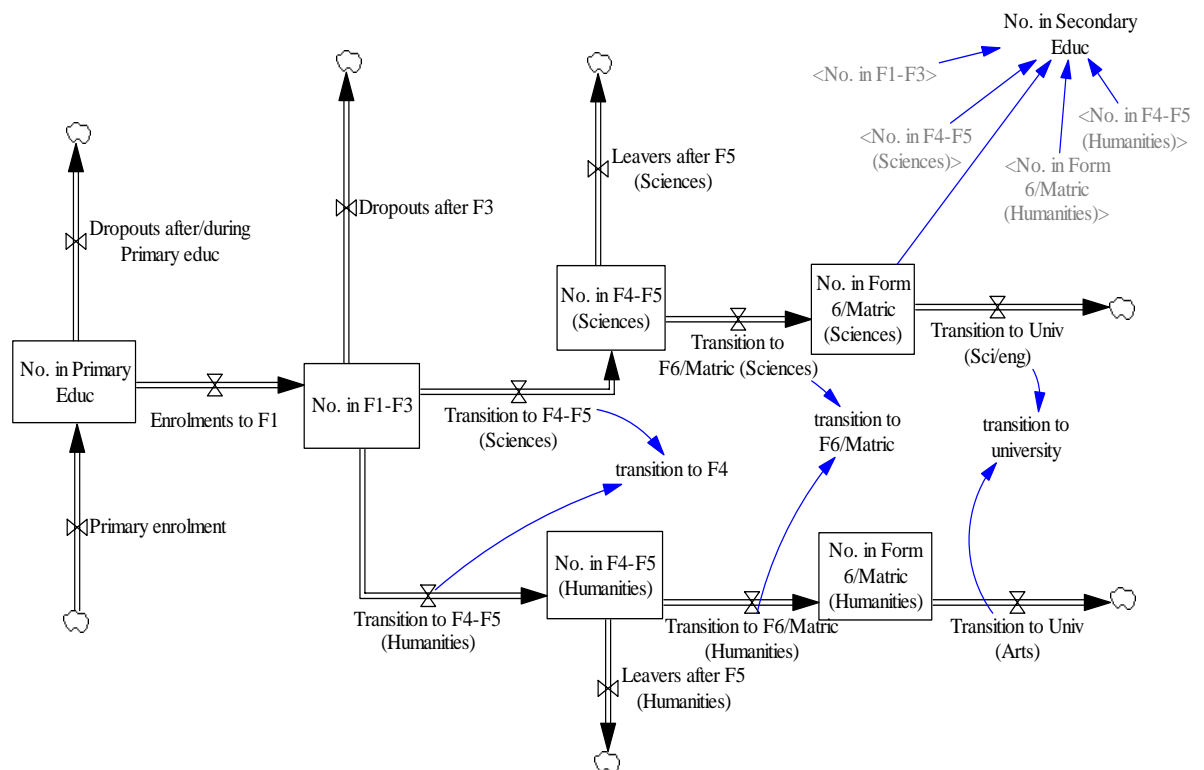

Figure 3. The Primary & Secondary Education Sector

There is a significant proportion leaving full-time education after F5. Attempts to address this are essential if the Sarawak economy is to prosper and if Malaysia as a whole is to attain developed status. An internal document suggested an estimate of 90% leaving education post-F5. However, it is believed that improvements in the proportion progressing to tertiary education have been implemented since the mid-1990's and so the figure of 0.9 is progressively reduced from the start of the model's runs. Experimentation here is obviously a highly critical aspect of our work: more students entering higher education is vital for the Sarawak's future as a potential knowledge economy.

Transition to higher education is an almost continuous progression once students have elected to carry on to Form 6 or, alternatively, elect the matriculation route. Those leaving after this point in their educational progression are negligible. No such leavers are represented in the model since the numbers are so small. Also, it has been assumed that the choice between humanities and sciences will then reflect their corresponding choices at university.

Once the student flow bifurcates after F4 there is a need to create aggregated variables. Thus the totals entering F4, F6/Matriculation and university are separately defined. Also the total in secondary education is introduced, made up the five individual model variables which are the sub-components of "number in secondary education".

The tertiary education sector is defined as universities and also technical colleges or polytechnics. In essence it is all those institutions offering full-time education programmes to students after the level of F6 or equivalent. The model of tertiary education developed for the current purpose is presented in outline in Figure 4.

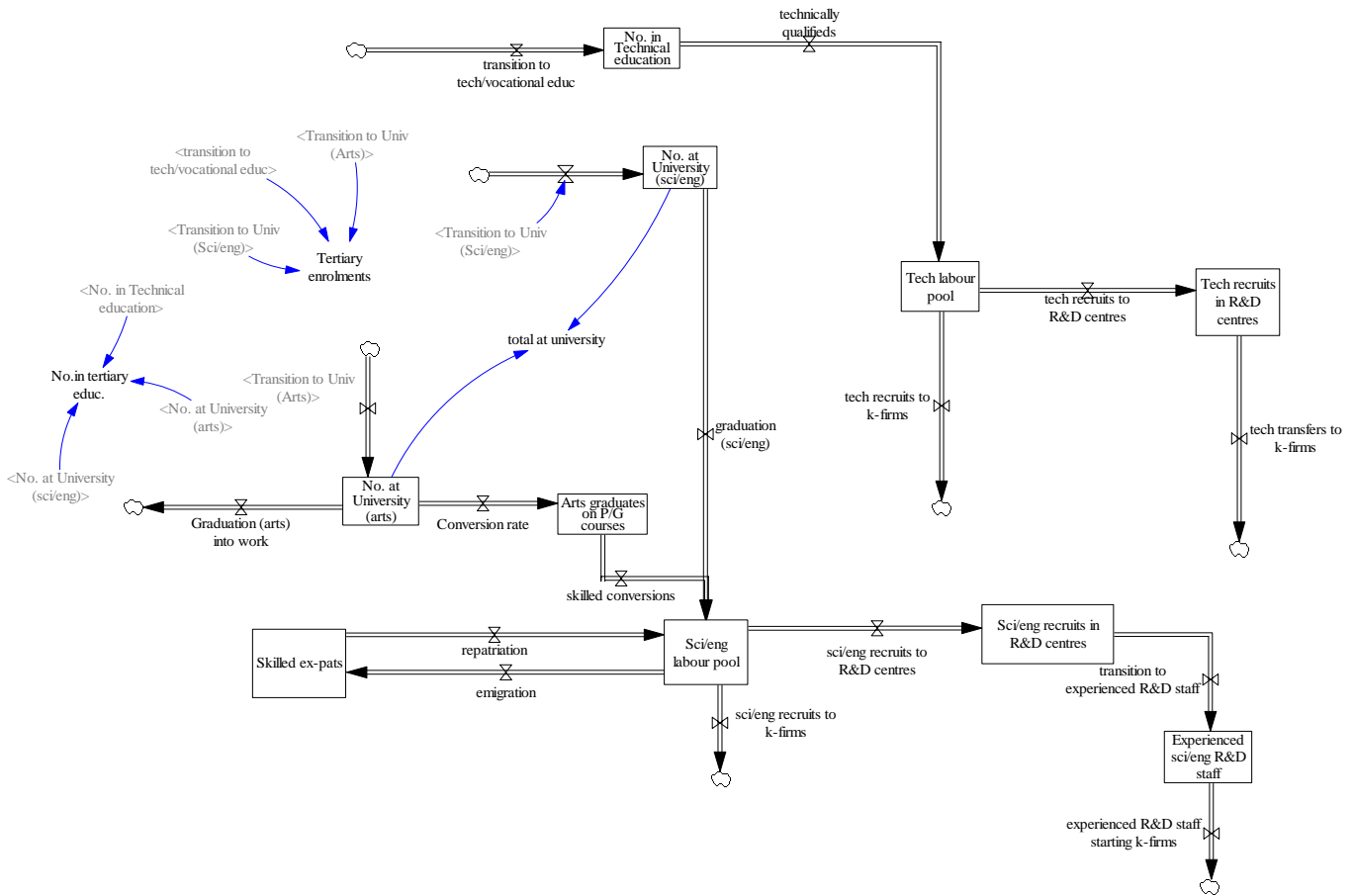

Figure 4. Tertiary education sector and consequent employment

Technical education is included. Knowledge-based firms require both skilled engineering and scientific staff but also technical support staff who have gained qualifications from the technical/vocational education institutions existing in Sarawak. By 1998 all secondary vocational schools were converted to State Technical Schools with around 1500-2000 students enrolled. However, the number of such schools in the whole of the State is less than ten. But it is progression on to higher technical education which is the element that underpins the knowledge economy and fulfils the necessary support role for qualified engineers.

After graduation there must exist job prospects, particularly for those qualified on the science and engineering side, for significant emigration to be avoided. If such graduates cannot obtain employment in Sarawak within one year, on average, it is assumed they will start the process of emigration. In addition to emigration a flow of repatriations is included. If the prospects and opportunities for skilled ex-patriots expand in Sarawak then it would be expected that some fraction would return to their homeland for employment and career progression. This will add to the skilled labour available to k-firms and to R & D centres.

Arts graduates can be re-trained and the existence of post-graduate conversion courses to equip them with some of the skills needed in knowledge-based employment is a possibility and is included in the sector. This initiative needs to be

progressed and it assumes a capability and willingness of the universities to mount it and, furthermore, government funding may also be required. In the event that (more) such courses are launched, there is yet another source of skilled labour available to k-firms.

The promotion of Research and Development (R & D) centres is a crucial segment of the strategy to transition Sarawak towards a knowledge-based economy. The source of the labour for these centres will come from the expanding scientific and engineering graduate output, backed up by suitable technical support staff. The government have a role to play in inaugurating start-up R & D centres and must be prepared to allocate financial resources accordingly. Over time the centres will acquire collective experience: they will 'mature'. It is these mature centres which both directly and indirectly will facilitate the supply of entrepreneurs to set up k-firms. In turn these k-firms will recruit from the scientific and engineering labour pool.

The training of scientific and engineering staff will necessitate more teachers at the level of scientific secondary education and at university. This is another career route for appropriately qualified new graduands and one which currently is not explicitly included in the model.

Workforce Sector

The Workforce Sector presented in Figure 5 aims to portray the quality of human capital available in the Sarawak economy. It defines five categories consistent with their highest level of educational attainment. Thus we have:

- No formal education
- Educated up to F3
- Educated to F5
- Technically educated post F5/F6 (Certificate & Diploma students)
- Numbers with Arts degrees
- Numbers with Science degrees

The category 'No formal education' covers those who have dropped out during or just after primary education (P1 –P6) or before commencing F1. Attaining just this level of education cannot be expected to help a move to a k-economy and so the description is justified in the current context. There currently appears to be a significant dropout at the F3 stage and this level of attainment is therefore specifically included. Those in the category 'Up to F5' education similarly have terminated their education after F5.

Tertiary education comprises those who have gone on to further or higher education post F5/F6. It comprises those in degree level education, either via F6 or through the matriculation route, together with those electing a technical education. The latter have an important supporting role to play in the development of a k-economy.

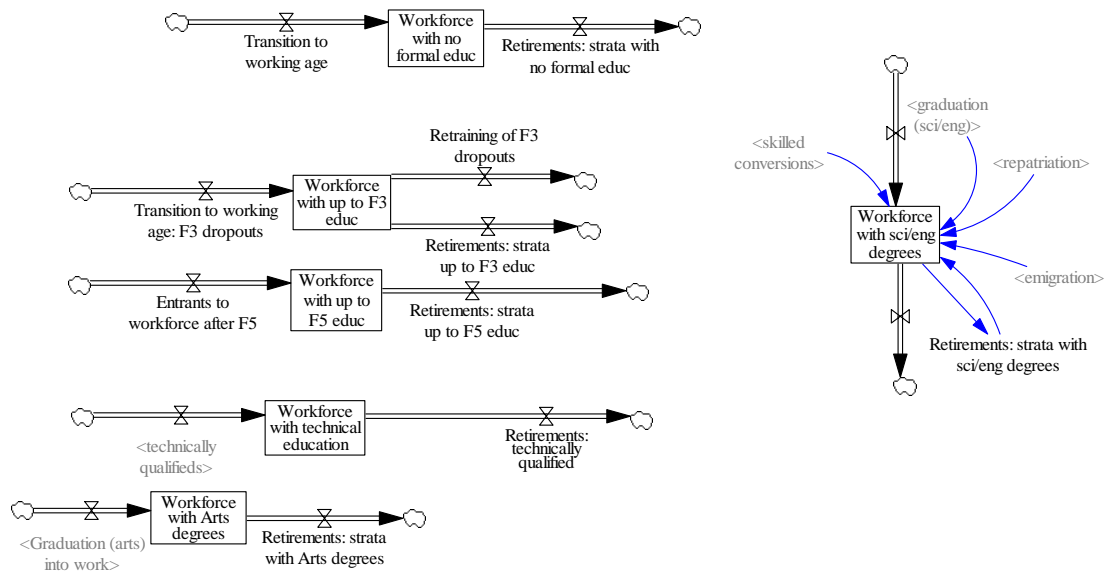

Figure. 5. The Workforce Sector: main view

Accumulating all the various categories together allows a calculation of the total workforce. In addition, weighting the proportions attaining each possible level of education against the total workforce allows a computation of the ‘mean years of education’. This is an important international measure of development and its improvement over the years is an indicator of Sarawak’s progression to developed economy status in line with Vision 2020 for Malaysia as a whole.

In addition to the above, there are various indices computed, such as the percentage of the workforce educated to tertiary level, to F3 level, F5 level and so on (Figure 6). The proportion of professionally-skilled workers and graduates per 1000 of population is another widely-reported index and this too is easily computed. ‘Professionally-skilled’ is defined as those with a university degree or other post-F5/F6 qualification such as a Diploma or Certificate.

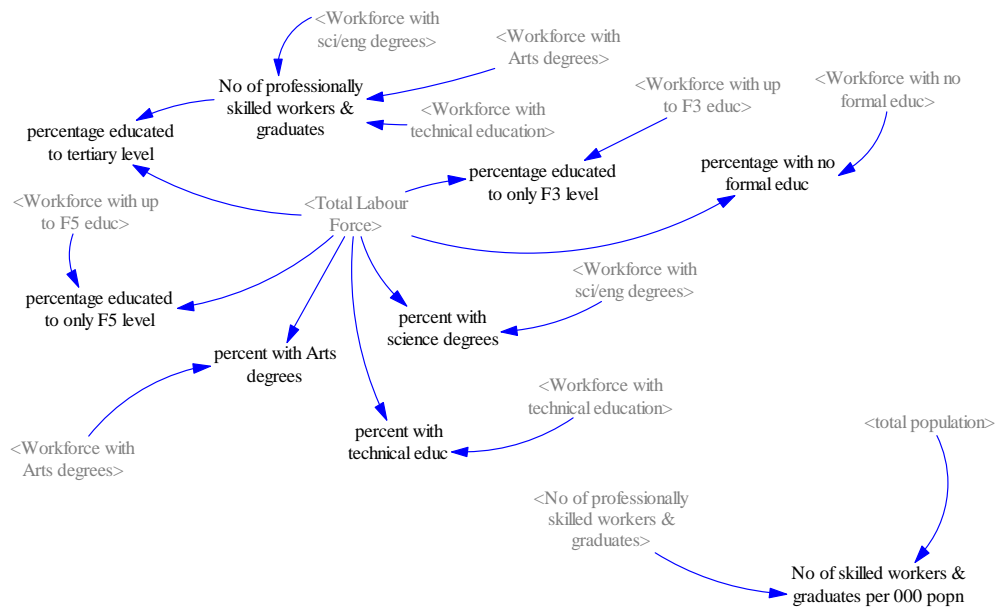

Figure. 6. Various percentages and indices computed for the workforce sector

Manufacturing, Construction and Service Sectors

This section describes the representation of the manufacturing, construction and service sectors within the model. The manufacturing sector is specified by disaggregating it into its important individual industrial components. It is not modelled globally. The separate sectors included are: ‘Electrical & Electronic (E&E)’; downstream timber processing; petroleum products; palm oil and sago (starch) production. (LNG & unrefined petroleum are categorized as part of ‘mining’ although these export-earning sectors are also included separately here.) The chosen groups cover 87% of the total gross value of manufacturing output in the State based on 2000 data. The construction industry is specified separately.

Figure 7 shows the structure adopted for E&E, Construction and services. The diagram is a simplified version of that incorporated within the model so as to aid comprehension.

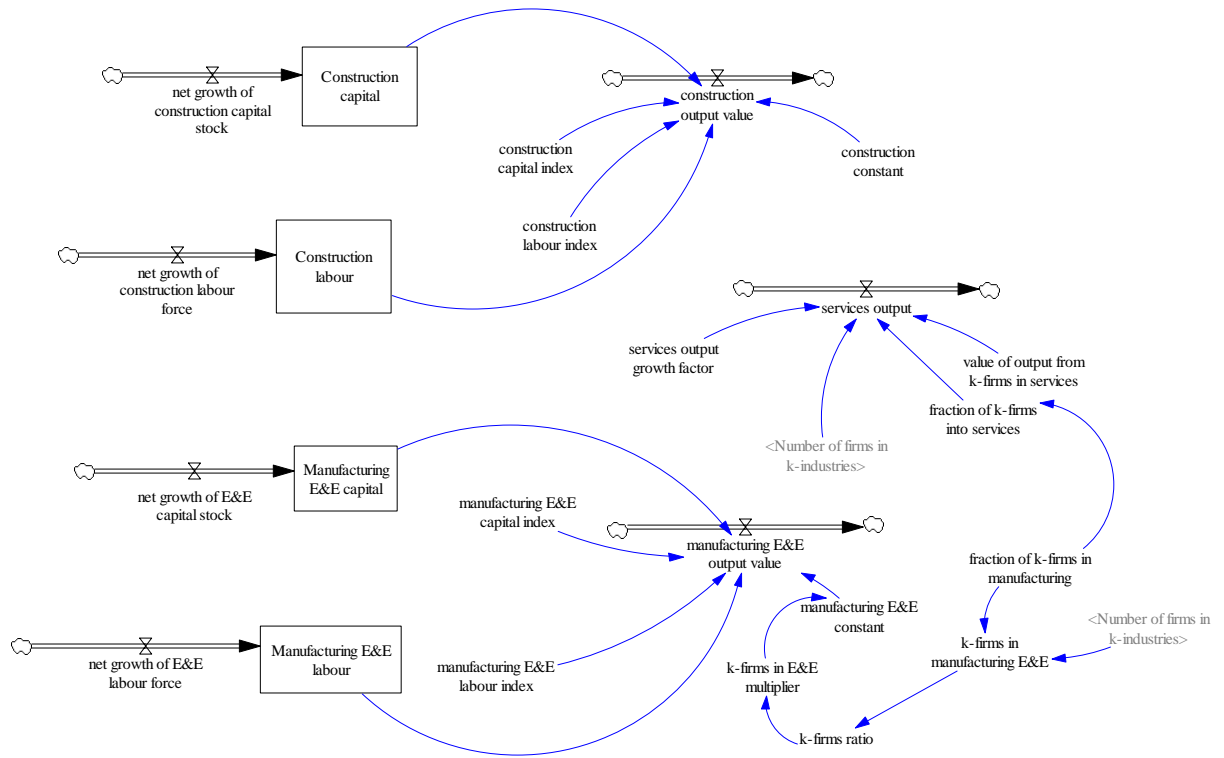

Figure. 7. Simplified view of the Electrical & Electronic Manufacturing, Construction & Service Sectors

A Cobb-Douglas production function is used to model E&E output and construction output. This type of function has a long history of use in economic growth models and it is flexible, being capable of exhibiting increasing, constant or diminishing returns to scale dependent upon parameter specification. The inputs which need to be specified are (i) a constant parameter (ii) a labour index and (iii) a capital index.

The sum of the indices determines the degree of returns to scale. At present, E&E is specified with increasing returns to scale. Inputs of labour and capital are estimated based upon a simple growth function and the numbers used equate with existing data on labour and capital in the E&E industry.

The influence of k-firms enhancing the output of the E&E sector is modelled by uplifting the constant value in the Cobb-Douglas function. This is in line with sound practice in economic growth theory. As the number of k-firms in the State gets bigger this will have a progressive effect on E&E output value.

The growth of services is set at 5% per annum and a compound growth function is adopted. An examination of the recent growth rates of the various categories of services reveals a significant variation from less than 1% to in excess of 12%. The choice of 5% per annum is indicative of the majority of sub-sectors. The emergence of a knowledge component in the service sector will enhance the output in excess of the 5% p.a. specified initially. The number of k-firms is split as between E&E manufacturing and services. Currently the ratio is 0.7 for E&E and 0.3 for services. This serves to emphasise that developments in a knowledge economy are not

restricted to ICT-based manufacturing industries but can, and are expected to, permeate into a range of service sectors also.

Output from the construction industry is modelled in the same way as the E&E sector in manufacturing. That is to say a Cobb-Douglas production function is employed and the labour and capital inputs over time specified by simple compound growth functions. Presently this industry has indices of 0.2 for capital and 0.5 for labour, the sum equating with decreasing returns to scale.

State Finances and GDP

The formulation of the State Finances and GDP sector follows a logical path: State income allows for State expenditure. Reserves, which are built up or run down as desired, exist as a buffer between the two flows. State income is derived from the tax take on various industries such as palm oil, timber and LNG, together with an allocation from the Federal government. This is split into operating funds and development funds. For instance a large slice of operating expenditure is devoted to education, social welfare and medicine and health.

For our purposes the flows of funds from different sources can be aggregated, although expenditure is necessarily split into operating expenditure and development expenditure. This is reflected in the diagram for this sector below.

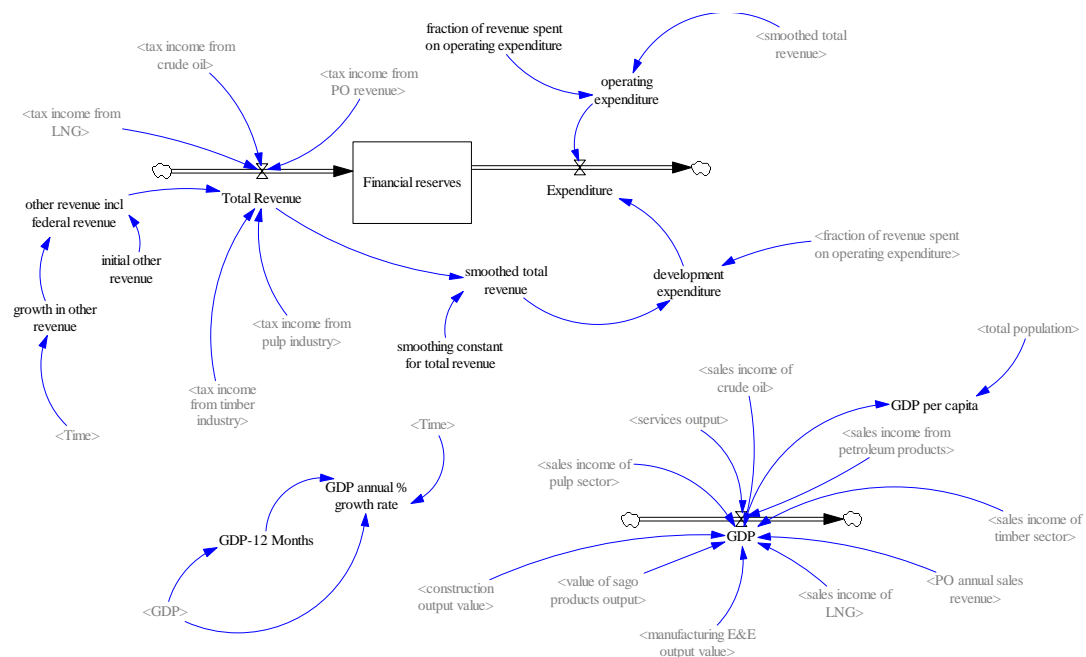

Figure. 8. State Financial sector together with GDP and GDP annual growth rate

Whereas development expenditure will normally follow development revenue allocations from the Federal government, as financial reserves allow it would be

prudent for the State government to take the initiative in releasing further monies for development. State R & D centres would be one such use of these funds.

The growth of 'other revenue', which covers all sources of revenue not derived from the State tax take on the industries specifically included in the model, is set to grow at 2.5% per annum from a base of 4 billion RM in 1995. It should be emphasised that the model is not aiming to faithfully reflect the full detail of financial flows into and out of the State Treasury, but rather to allow a consideration of variations in development expenditure, the primary engine of endogenous growth.

Gross Domestic Product is formulated by aggregating the output data from ten separate industries and sectors specifically included elsewhere in the model. The availability of total population data from the population sector means that GDP per capita is readily computed. It is common to find annual GDP growth rates in all countries' published data and so this measure is also included. It is worth repeating that *all* monetary data is specified in real terms based upon 1995 prices, the starting point for the all the simulation runs.

Research and Development and the K-industries Sector

The genesis of the emergence of the k-economy is to be found in R& D. Here is the instrument which any government in a developing country can deploy in order to effect an economic transformation. The sequence is normally to provide seedcorn funding for 'start-up' R & D centres which are staffed by qualified engineers backed up by technical support staff. These centres may not necessarily be ICT manufacturing industry based, but may embrace elements of the service economy such as health and biotechnology.

Whatever the nature of the activities ongoing in the R & D centres, they all require a supply of skilled engineers, technical backup and a high-tech ICT infrastructure. These three components are specifically included as all three together represent a necessary and sufficient condition for R & D centres to emerge. However, the creation of k-firms requires, additionally, *experienced* high-tech engineers and scientists. Where such people are not available the k-firms need to source their expertise from outside of Sarawak. Endogenous growth of k-firms therefore is restricted in the absence of a supply of experienced engineers and scientists. Raw graduates, however appropriate their degree subject, do not equate with experienced staff.

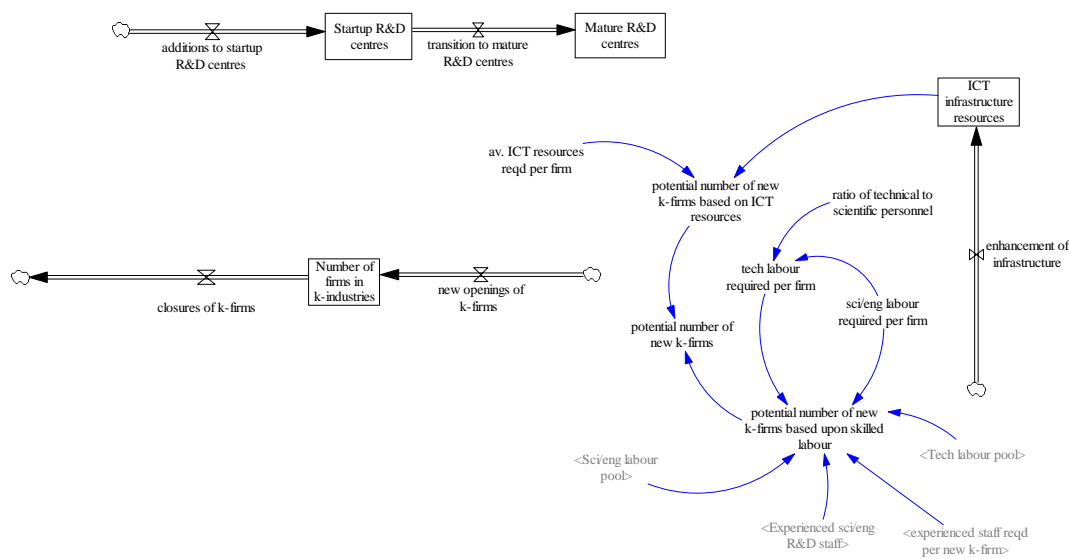

Figure. 9. Research & Development Centres, knowledge-based firms and the ICT infrastructure (simplified from that in the model)

The diagram above shows that ‘start-up’ R&D centres eventually mature over a period of years, assumed to be on average five years, and it is from the mature R&D centres that a source of experienced high-tech staff will emerge. Start-up centres are assumed to require 20 scientists and engineers, with a further 30 being employed as the centres mature. Each start-up R&D centre is estimated, on average, to cost RM5 million to set up, the number of such schemes being determined by the overall annual Statebudget for R&D.

The role of the technical backup staff, both in R&D centres and, more significantly, in k-firms should not be underestimated. Within Sarawak there are indications that the supply of this element in the workforce could be constraining the State’s development. We have assumed that, for both R&D centres and k-firms, the technical labour force is 20%. In other words, there would be one technical officer for every five qualified engineers and scientists.

Remaining sectors

For the sake of brevity the remaining model sectors are not described in detail. These sectors comprise those which make up the current resource-based economy in Sarawak. Timber is a prominent example along with the emerging pulp wood industry. Palm oil is a prominent export earner and its yield comes from oil palms planted in clearings as hardwood trees are felled. However, there is considerable attention paid to the sustainability of the hardwood species and forestry is managed closely by the government. This also applies to land made available for oil palms.

Along with the timber resources there are mining resources which contribute significantly to GDP. Oil and petroleum products is one case in point together with

liquefied natural gas (LNG) which is exported to Japan. In 2003 crude petroleum and LNG together accounted for some 63% of Sarawak's exports by value (Source: Sarawak Facts & Figures, 2003/2004). In contrast timber logs and sawn timber contributed 7.5% in 2003, down from almost 28% in 1990 and reflecting the government's management of timber resources referred to above. Within the timber industry the development of plywood and veneer products (higher value-added items) has offered a counterpoint to the situation with logs and sawn timber. Plywood and veneers accounted for almost 9% of exports in 2003.

Specimen Scenario Runs

Introduction

There are innumerable scenarios which can be undertaken with the model as currently configured. It consists of a total of 15 sectors (sometimes called 'sketches' or 'views') and in excess of 450 individual relationships, parameters and mappings. In keeping with the objective of the model purpose, we restrict consideration to those changes which impact most closely on the knowledge economy.

Reduction of dropout rates from various stages of education.

Here we have assumed that the major crisis points for dropouts, namely after or during primary education and after lower secondary education (F3), are addressed. Over the years of the 9MP we assume that in the case of primary school dropouts this is reduced to just 5% by 2010 and for F3 dropouts to just 2%. Also, the improvements in shifting the proportion doing science and engineering at university, a near doubling from 20% to just under 40% (over 1997-2004) are incorporated.

The effects on enrolments in tertiary education are notable, allowing over 6,000 extra students per annum by as early as 2015 (see figure 10). It must be stressed that this is without any reduction being made in those leaving after F5. Although there has been a reduction in F5 leavers in recent years, bringing the proportion down from 90% in 1995, it is still quite high as compared to normal progression rates to tertiary education in developed nations.

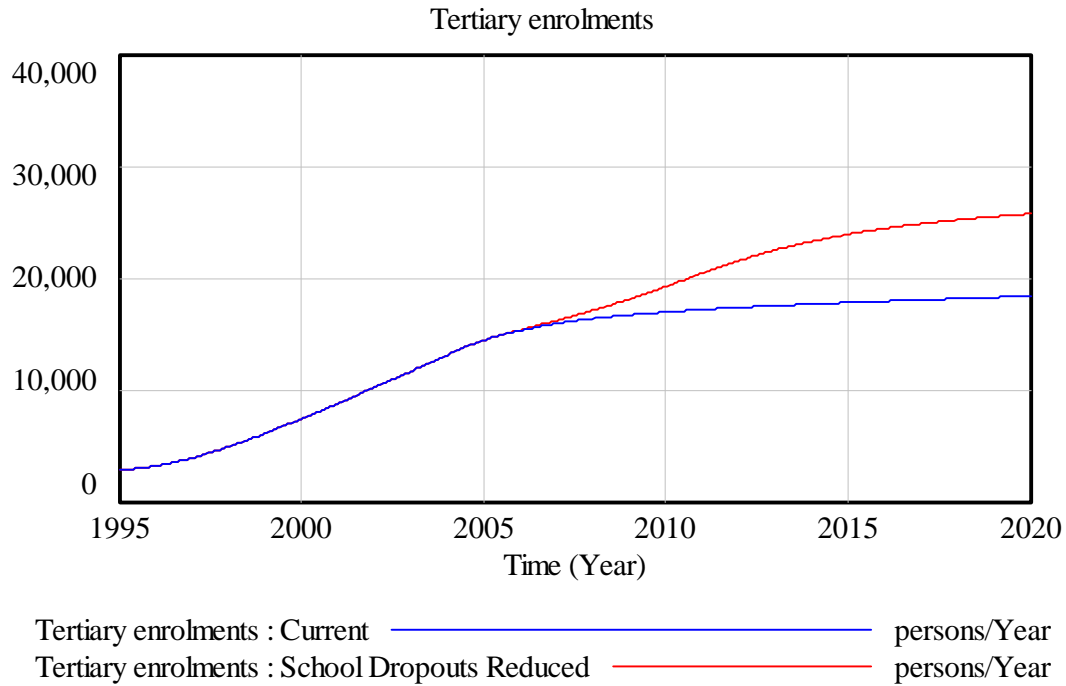

Figure. 10. Increased enrolments in tertiary education after school dropouts reduced

The beneficial effects of these extra additions to tertiary education follow the obvious links of cause and effect. Providing the ICT infrastructure is adequate then this extra stream of students will permeate through the economic system and, with many more becoming scientists and engineers, this will mean more k-firms opened and consequent improvements in GDP. The latter aspect is charted below (figure 11). It is interesting to note the delayed effects. The policy to reduce school dropouts was assumed to be initiated in 2005, but we do not begin to see the effects on GDP until around 2017.

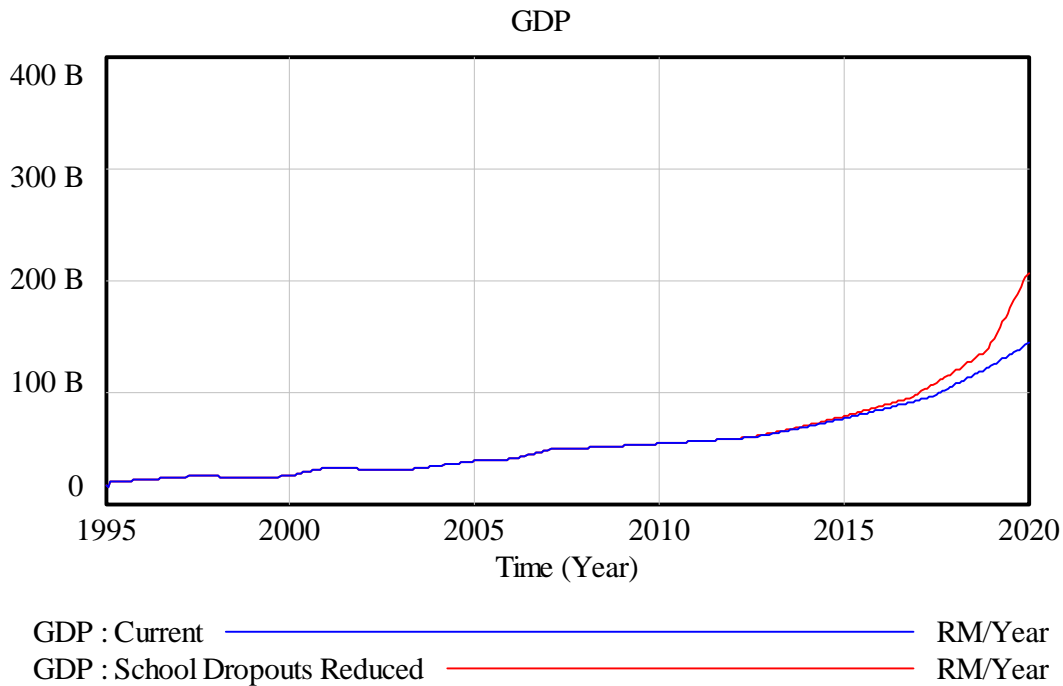

Figure. 11. Effect on GDP of a reduction in school dropouts

A policy precept can be asserted: **resources should be found to address dropouts at both the P1-P6 and F3 stages of education with a view to adding to the initiatives already undertaken in this regard.**

Re-training of F3 dropouts for Technical education

Over the past, before the policies designed to tackle lower secondary dropouts was invoked, there has been a cohort of young people who have already entered the workforce with a limited secondary educational attainment. Our estimates are that as many as 150,000 persons in the Sarawak labour force would come into this category in 2005. It was thought by many that this pool represented a resource to the economy that is being wasted: they could be given further training and enter the technical labour force. Recall that this often ignored sector of the labour force is vital to the evolution of a knowledge economy. We are assuming that each k-firm or R&D centre employing 100 engineers will also require 20 technically qualified people.

This scenario assumes that a modest increase of 500 per year of the F3 dropouts are now being placed into technical education. By 2010 this means 2,500 per year will be entering technical education. The change has the effect of both reducing the numbers educated to only F3 (see figure 12) as well as increasing the percentage of the workforce with a technical education.

Effects of retraining on numbers in technical education

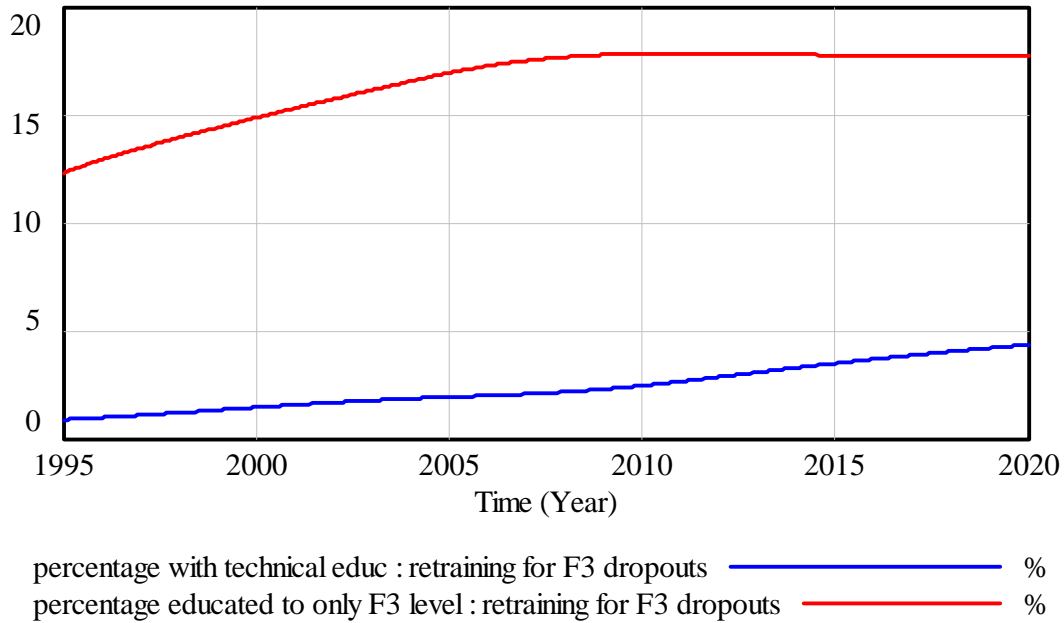

Figure. 12. Percentage with technical education and with only lower secondary education

Unfortunately there is a limited impact in terms of the knowledge economy. Unless the numbers of scientist and engineers are also increased, these newly-retrained technicians enter the technical labour pool but are not employed in a high-tech environment. They can contribute to economic development in other ways (such as motor engineers) but the evolution of k-firms and R&D centres requires action across more than one front. At present the supply of labour skilled in science and engineering is not stretching the requirements for the numbers of technically qualified persons. This is not to denigrate the policy of retraining. The economic benefit to the individual is accepted (and there is an economic benefit to the State also but which is not explicitly captured in this model which addresses the k- economy). The policy precept is: **retraining of F3 dropouts as technicians needs to be accompanied by increases in the numbers of science and engineering graduates if the additional supply of technicians are to gravitate to employment in the high-tech sectors of the economy.**

Increasing R & D expenditure

It is instructive to assess the effects of an increase in R & D spending. The method by which a k-economy can evolve is through increasing the number of experienced engineers by nurturing their capabilities in State-financed R & D centres. Accordingly it might be expected that to increase the proportion of development expenditure committed to R & D would be a beneficial policy.

The outcome of this policy is counter-intuitive. To see the basis for this assertion consider a policy to increase the percentage of development expenditure devoted to R & D, currently 1.5% p.a. (assumed), to 2%. This is accomplished in two ways: firstly by gradually increasing the percentage to 2% over a five-year period from 2005-10 and, alternatively, by stepping up the percentage to 2% abruptly from 2005.

The policies have a clear beneficial effect upon the number of R & D centres as can be seen from figure 13.

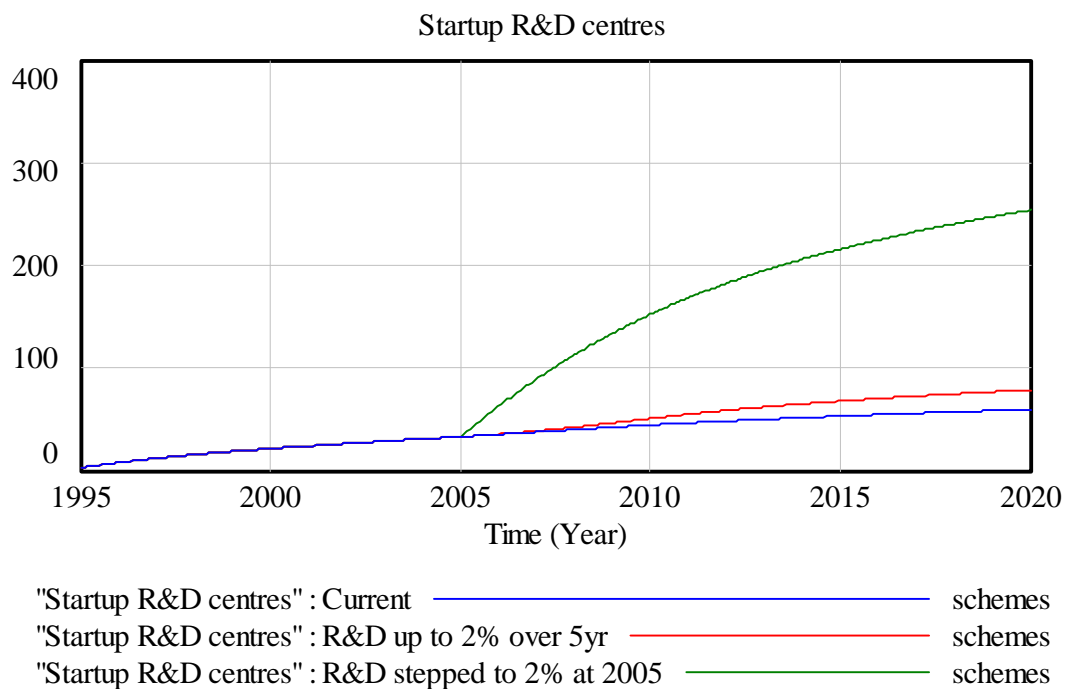

Figure. 13. Effects of increased R & D spending on startup R & D centres

But this policy attracts many of the highly skilled scientists and engineers into R & D on graduation from university. Consequently there is a surplus in that sector which crowds out the correspondingly fewer skilled persons available to become employed in k-firms. The numbers of experienced engineers is far in excess of what is required to found new k-firms as compared with the outflow of 'raw' graduates, which are then in short supply for k-firm startups.

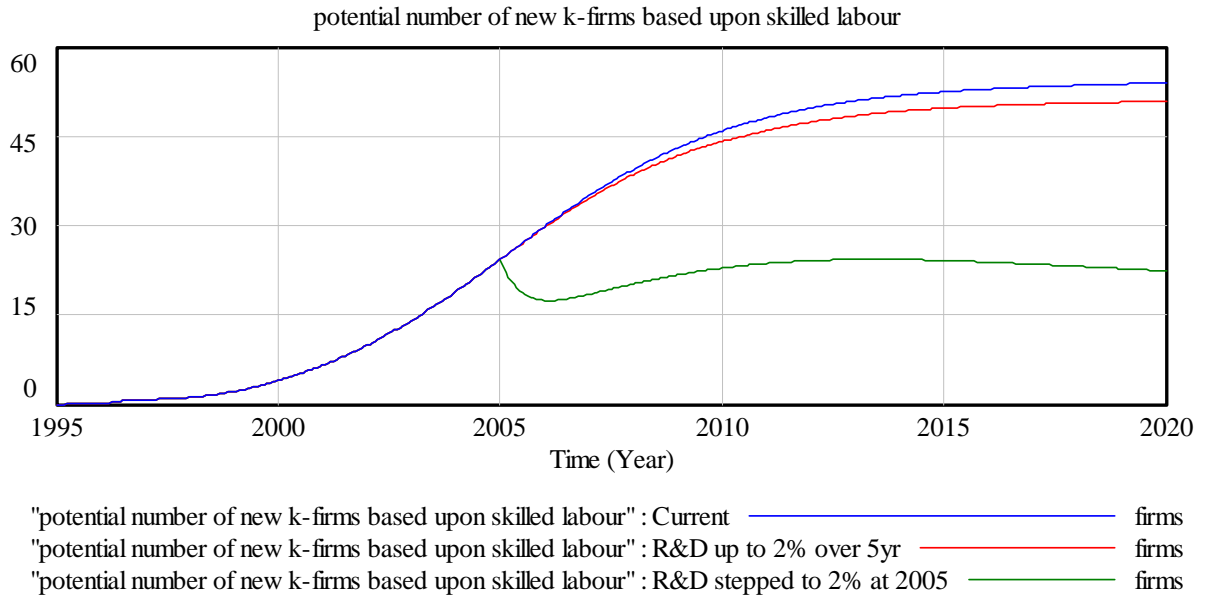

Figure. 14. Effect of increased R & D spending upon the potential number of new k-firms

We see the effect conveyed through figure 14. The number of potential new k-firms is depressed under the raised R & D policy because there is not the supply of new graduates to accompany the experienced ones. As with the conclusion in the previous section, action must be taken more systemically if the policy is to be effective. Besides an increase in the quantum of R & D spending, a move to increase the supply of science and engineering graduates is also called for.

A final graph on the effects of this particular policy initiative is to portray what might be suspected from examining figure 14. The number of firms in k-industries is indeed lower under the increased R & D spending policy (see figure 15).

An additional insight here is that the choice of the rate of change in R & D spending is also important. The policy option of phasing the change in over a period of years, rather than abruptly changing the percentage, while still being inferior to the base case with respect to the number of k-firms in the economy, at least is not as detrimental as is the abrupt change. A slower phased approach would also allow for concomitant changes to increase the supply of graduates trained in the sciences and engineering.

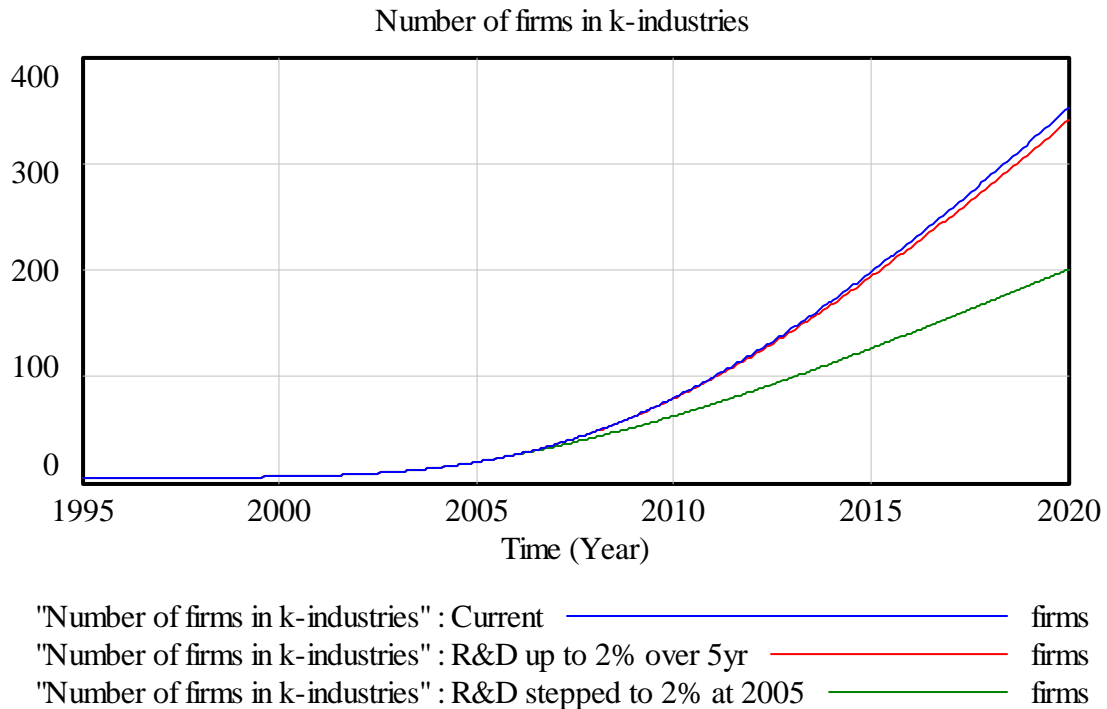

Figure. 15. Effect of increased R & D spending upon the number of k-firms

The policy precept here is: **increases in R & D spending, to allow more State-financed startup projects, need to be phased in over a period of years with concomitant increases in the supply of high-tech graduates to avoid a skewing of skills towards R & D centres, which thereby constrain the growth of new private sector k-firms.**

Microworlds: sharing and disseminating insights from complex system analysis

Introduction

System dynamics models can lever insight in complex systems such as an economy. However, it has been recognised that there is a need to promulgate those insights beyond the confines of the modelling team. To thrust a model into a policy support role means more than conducting experiments in workshop situations. The assembled audience, despite being impressed, may not be entirely convinced because the agenda may look to be well-rehearsed.

With an official as high as the State Secretary requesting the model be made available on his own computer, it was essential that we delivered a platform which would allow of easy use, but still have the potential to deliver insights. Thus it was decided to create a microworld shell around the model. This would allow anyone to run, experiment with and, crucially, reflect upon the results without interference by the modelling team. If the model was truly to leverage insight and stimulate thinking that would result in policy interventions then it was considered that the greater likelihood

of this outturn would stem from personal interaction with the model by State officials rather than a guided programme offered by the modelling team. A Venapp environment in the Vensim software (at the Decision Support System version level) allows this enhancement.

The concept of the microworld in system dynamics was initially highlighted and explained by authors such as Morecroft (1988) and Kim (1992). It has since been extended to allow an element of competition between participating teams who are allowed to intervene and make various decisions as the model progresses. In these circumstances the entire package is usually sold as a commercial item and is used in generic training exercises rather than the dedicated policy support role envisaged here.

In the figures which follow, various screen shots (figures 16-19) are depicted which reflect the way in which a State official would interact with the model and the nature of the tasks allowable in the context of the microworld. The main menu (see figure 16) allows the user to view the stock-flow diagrams, examine the past data against simulated model output. As the model runs from 1995 to 2020, the comparison against data is currently restricted to, at most, some ten years. Scenario runs can be set up using simple slider bars and the results depicted for a collection of the important variables in the model. Finally it is possible to see the formulation of the relationships expressed in the model using the causes and uses trees available as standard in the Vensim software tool.

System Dynamics Analysis Tool for Sarawak KE Development

Main Menu

Acknowledgement
View Stock and Flow Diagram
Baseline Simulation and Historical Data
Set and Perform Scenario Runs
Analyze Causal Relationships

The software you are using allows you to explore the behaviour and sensitivity of the Sarawak model developed in CORAS, the University of Salford. The software allows you to explore the model by means of buttons, menus, and output screens. To activate a button, or to select a menu item, click on it.

Exit the tool

Figure. 16. The opening screen depicting the Main Menu

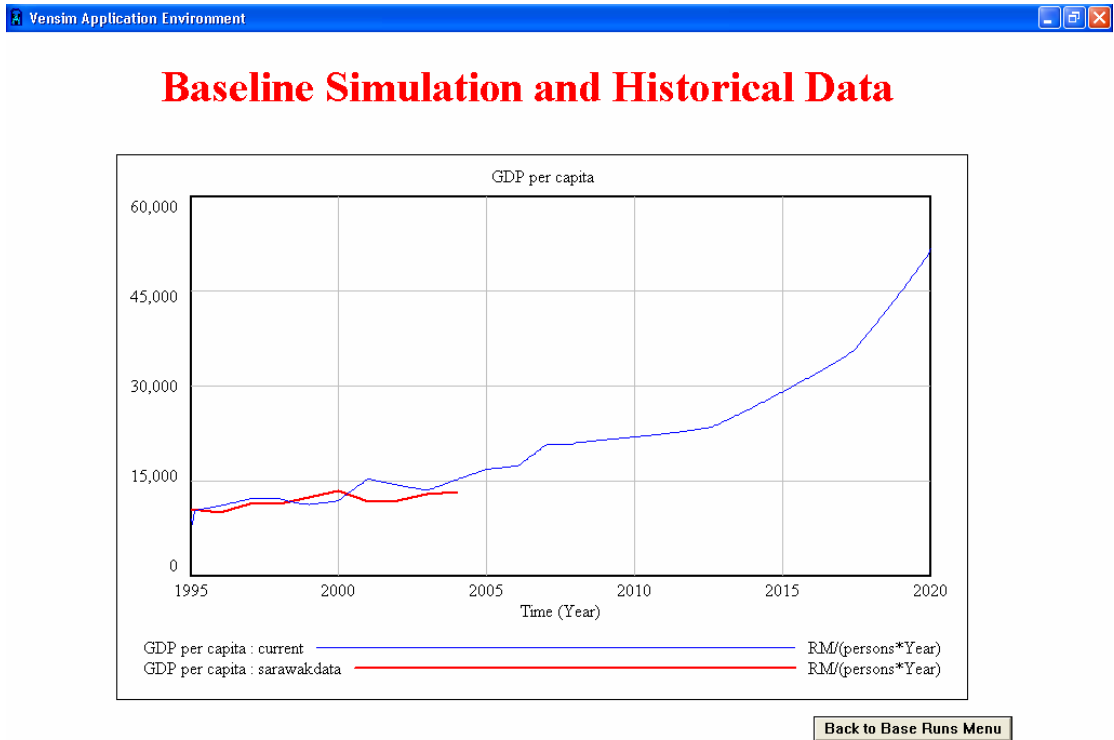

Figure. 17. A screen showing the comparison with past data feature

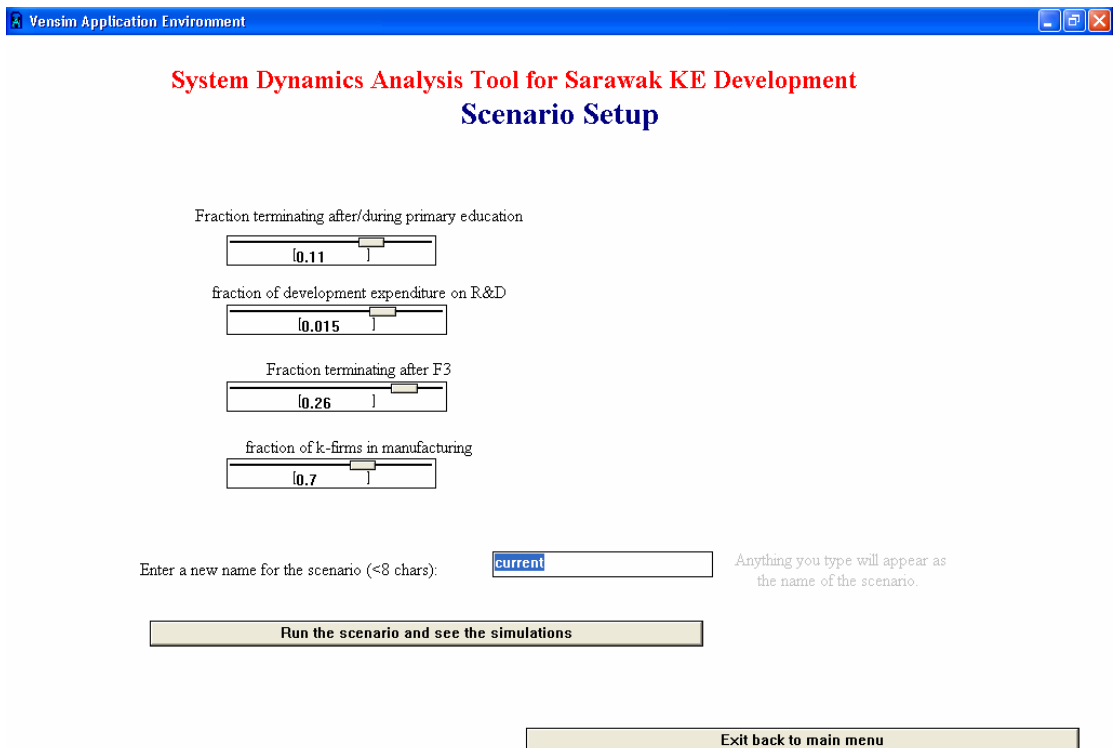

Figure. 18. Slider bars allow the alteration of parameters prior to scenario runs

Scenario Simulation

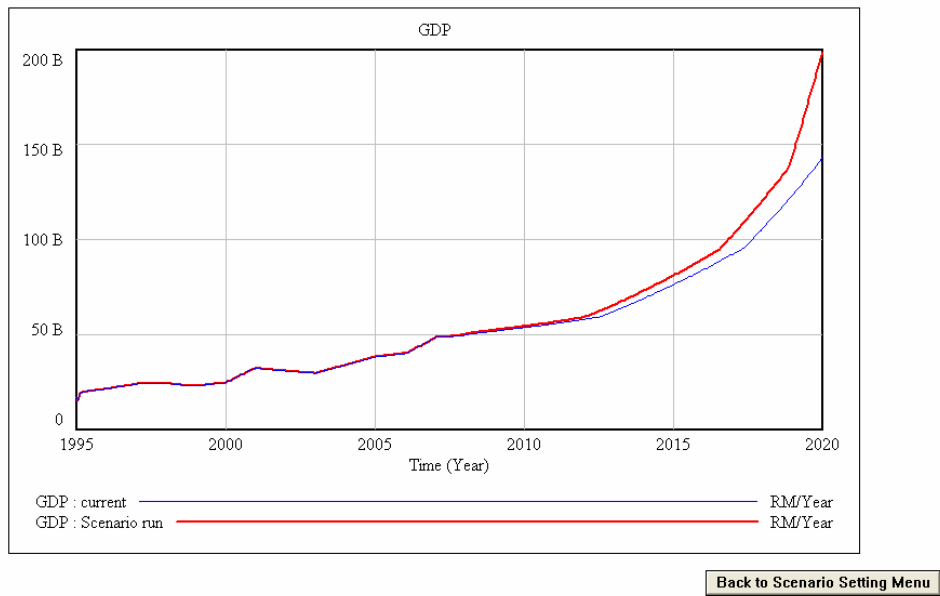

Figure. 19. The results from a scenario run

Conclusions

The paper has described an empirical study conducted over 27 months and which has resulted in an SD tool for macro-economic planning being made available in a developing country. Prior to this there was little or no use of formal modelling techniques although the collection of a proliferation of statistical data was evident. As well as the availability of the tool, knowledge of the capability of system dynamics as a modelling methodology has taken root, reinforced by a technology transfer element in the project. It is confidently expected that further policy issues of concern to the Sarawak State government will also be subject to analysis using the SD methodology.

References

Barney G O (2003) Models for National Planning. In *Proceedings of the 2003 International Conference of the System Dynamics Society*, New York (CD-ROM). See also www.threshold21.com (accessed May 27 2005).

Black F (1982) The Trouble with Econometric Models. *Financial Analysts Journal*, March-April, 29-37.

Chen JH and Jan TS (2005) A System Dynamics model of the Semiconductor Industry Development in Taiwan. *Journal of the Operational Research Society* **56**: 1141-1150.

Dangerfield BC (2005) Towards a Transition to a Knowledge Economy: how system dynamics is helping Sarawak plan its economic and social evolution. In: *Proceedings of the 2005 International System Dynamics Conference*, Boston, USA. (CD-ROM)

Kim DH Ed. (1992) Management Flight Simulators: Flight Training for Managers (Part I). *The Systems Thinker* 3(9): 5.

Meadows DH and Robinson JM (1985) *The Electronic Oracle*, Wiley, New York.

Morecroft JDW (1988) System Dynamics and Microworlds for Policymakers. *European Journal of Operational Research* **35**: 301-320.

Morgan P. (2005) *The Idea and Practice of Systems Thinking and their relevance for capacity development*, European Centre for Development Policy Management, The Netherlands.

http://www.ecdpm.org/Web_ECDPM/Web/Content/Navigation.nsf/index2?readform&http://www.ecdpm.org/Web_ECDPM/Web/Content/Content.nsf/0/358483CE4E3A5332C1256C770036EBB9?OpenDocument (February 24, 2006)

Parikh KS (1986) Systems Analysis for Efficient Allocations, Optimal Use of Resources and Appropriate Technology: some applications. *Journal of the Operational Research Society*, **37:2** 127-136.

Rebelo I (1986) Economy-wide Models for Developing Countries, with emphasis on Food Production and Distribution. *Journal of the Operational Research Society*, **37:2** 145-165.