

SYSTEM DYNAMICS RESEARCH TO CHINA'S INFLATION

Yan Guangle
System Dynamics Group
Shanghai Institute of Mechanical Engineering
Shanghai, CHINA

ABSTRACT

Inflation is one of the most troublesome problems China is recently faced with in the course of the economy reform. The inflation takes place in the form of general price rising. It becomes more and more serious and is greatly obstructing the healthy development of China's economy. This situation results from many factors including the biased trend of the reform strategy, the deviations in implementing policies, the defects of the economic system, etc. The conventional theory about money amount has been used to analyse inflation before. This analytic method specially indicates the view point that inflation with no exception is a kind of money phenomenon by stressing the causal relationships between money amount and general price level, but it considers money supply as an exogenous variable controlled by the government's policies and ignores the effects and restrictions from other economic factors. Therefore there are some limitations of this method in real uses. For this reason a new approach of system dynamics is put forward in the present paper. A dynamic model composed of a monetary market section, a commodity market section and a regulation section is developed. On the model a series of policy tests mainly concerning the two economic levers of price and interest rate are simulated with the consideration of China's special situations. The causes and mechanism of China's recent inflation are analysed and some policy suggestions are also made for eliminating or controlling the inflation. The results of this paper may provide worthwhile references for China's further economic reform.

I. Introduction

Serious inflation is constantly considered as an evil by almost every one. Inflation breaks the balanced development of national economy, deteriorates social economic environments, and brings catastrophic results to people's life. By the statistics the increase rate of the total volume of retail sales of China has continuously been over the range of the moderate inflation for four years. Moreover the statistics does not yet include those affects of hidden-form inflation caused by inappropriate policy controls. Of course, there are many factors that leads to inflation. For now, the first thing lies before us is to analysis these factors and to seek the way how to halt or to decrease the

inflation in order to ensure the healthful development of our national economy.

In the past, economic problems were mostly dealt with by qualitative analysis or partially quantitative analysis. While in the reality more extensive studies to complex economic system are required. In the present paper we try to explore the inflation mechanism by the aid of system dynamics, which is good at dealing with high order, multiloop and nonlinear systems.

Generally speaking, an economic system is composed of commodity, monetary, debenture and work-force, the four markets. However, in China, debenture market is just at its initial stage, and work-force does not form even a market. So our model in this paper involves only a commodity section, a monetary section and a regulation section. One of the most remarkable characteristics of China's economy is partially planned and partially marketable. The base run of our model is finished under the assumption of full market economy for convenient comparisons. Some relative policy tests mainly concerning interest rate and price level are made. The flowchart of the model is shown in Figure 1. From the Figure we can see that in the model there are nine Levels:

MS----Money Supply;
 TRAND----Transaction Demand in money demand;
 SPECD----Speculation Demand in money demand;
 IR----Interest Rate;
 P----Price level;
 C----Consumption;
 S----Commodity Supply;
 INV D----Investment Demand;
 GNP----Gross National Production;

and some Auxiliaries:

MD----Total Money Demand;
 P*D----Total volume of retail sales;
 SAV----Savings;
 IBEN----Investment Benefit;
 PROD----Productivity;
 ACCU----Accumulation;
 D----Total Demand;
 MDISC----Deviation between money supply and demand;
 DISC1----Deviation between commodity supply and demand;
 DISC2----Deviation between investment demand and savings;
 DISC3----Deviation between investment benefit and interest

rate;

WORKS----Work force, a table function of time;
 TP----Total Production.

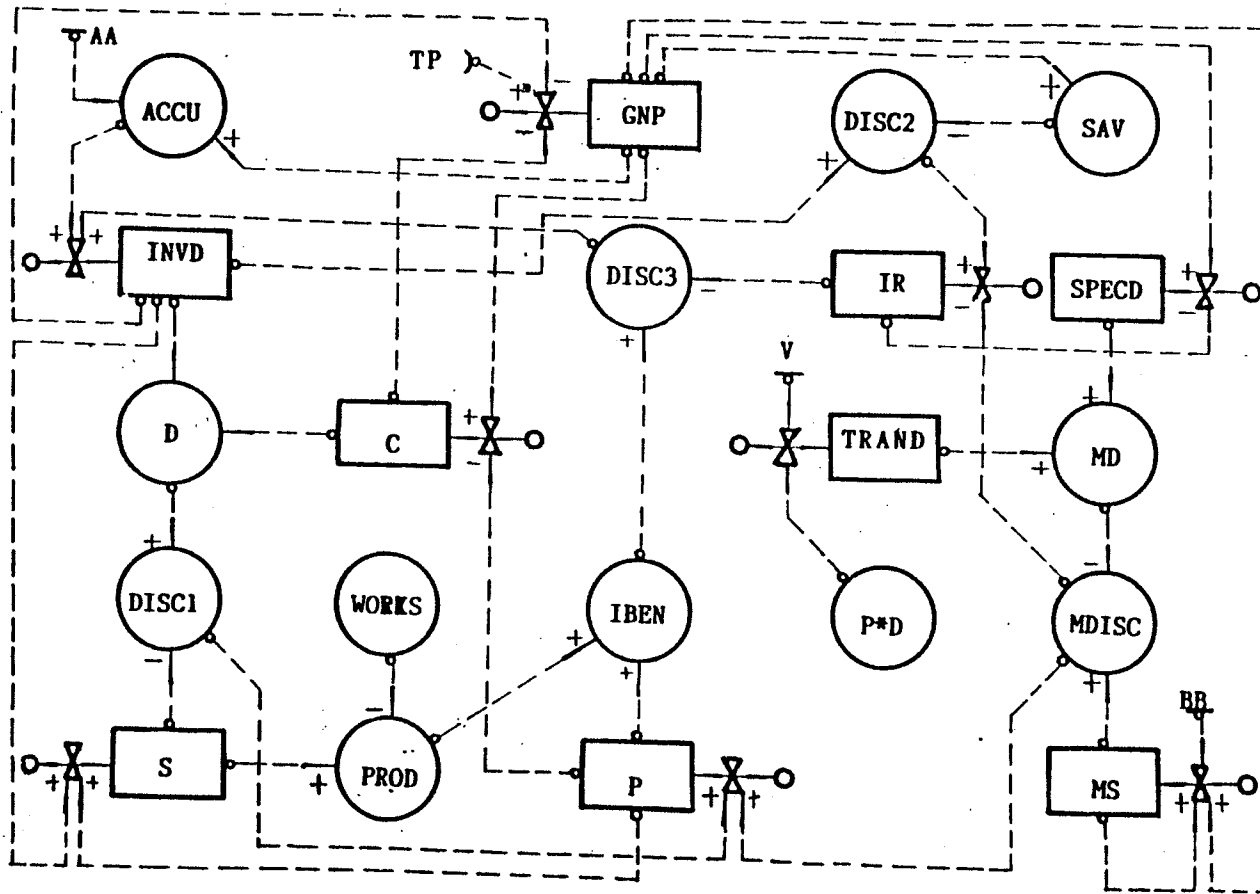

Figure 1. Flowchart of the model

II. Modelling

As can be seen in Figure 1, there are three sectors in the model. The monetary sector and commodity sector are the essential parts of the model. They have either relative individualities of their own or a close connection with each other through the another sector, the regulation sector. The variable of the gross national product (GNP) plays an extremely critical role in the model. It is the soul of the whole economic system.

1) Monetary Sector

In the monetary sector the money supply (MS) is controlled only by GNP. The money demand (MD) is, in theory, made up of transaction demand (TRAND), speculation demand (SPEC D) and prevention demand (PROVD). Because the prevention demand of money in China is relatively small compared with the other two demands, we combine it into TRAND. Here we use the classical money amount function:

$$MD = TRAND + (PROVD) + SPEC D \\ = P * D / V + k * P + h / IR$$

where V stands for the circulative speed of money, k and h are constant factors. MD is controlled both price level (P) and interest rate (IR) through the following two information feedback loops:

by P:

$$MD \text{ ----> } MDISC \text{ ----> } P \text{ ----> } TRAND \text{ ----> } MD$$

and by IR:

$$MD \text{ ----> } MDISC \text{ ----> } IR \text{ ----> } SPEC D \text{ ----> } MD$$

That is, The two economic levers of price and interest rate affect MD at the same time. P affects MD through TRAND and IR through SPEC D.

2) Commodity Sector

In the commodity sector the total demand (D) is made up of consumption demand (C) and investment demand (I):

$$D = C + I$$

The lever of price dominates both commodity supply (S) and consumption demand (C) through the information feedback loops as follows:

for S:

$$S \text{ ----> } DISC1 \text{ ----> } P \text{ ----> } S$$

and for C:

$$C \text{ ----> } D \text{ ----> } DISC1 \text{ ----> } P \text{ ----> } C$$

While the investment demand (I) is under the control of both price and interest rate:

controlled by P:

$$I \text{ ----> } D \text{ ----> } DISC1 \text{ ----> } P \text{ ----> } IBEN \text{ ----> } DISC3 \text{ ----> } I$$

and controlled by IR:

$$I \text{ ----> } DISC2 \text{ ----> } R \text{ ----> } DISC3 \text{ ----> } I$$

3) Regulation Sector:

There are five information feedback loops dominated by GNP in the regulation sector. They regulate consumption demand, accumulation, investment demand, savings, money demand, money

```

supply, etc. The loops are:
for C:
  C ----> GNP ----> C
for ACCU:
  ACCU ----> I ----> GNP ----> ACCU
for SAV:
  SAV ----> DISC2 ----> IR ----> DISC3 ----> I ----> GNP ---->
  ----> SAV
for MD and I:
  MD ----> MDISC ----> IR ----> DISC3 ----> I ----> GNP ---->
  ----> SPEC D ----> MD
for MS:
  MS ----> MDISC ----> P ----> C ----> GNP ----> MS

```

III. Interest Rate Tests

During the process of modelling, we find interest rate, on one hand is inversely proportional to the deviation between money supply and demand (MDISC), and on the other hand is directly proportional to the deviation between investment demand and savings (DISC3). When interest rate remains constant and low (say, $IR=0.05$), the behavior of MDISC tends gradually to be big, and both investment demand and consumption demand expand. When interest rate becomes regulatable and rises to a relative high level (say, $IR=0.12$), the deviation between supply and demand both in commodity section and in monetary section tends to be declined.

In fact, in China low interest rate policies have been implemented for a long time. The time value of money is ignored. Investors can take no note of economic profit and productive cost, and expand reproduction unchecked. With the economic expansion the investment desires become more and more strong. In addition, there exist some disadvantages in the conventional economic system of China. The central bank is not individual as it should be. It can not give full play to restraining loan scales. There is not a clear line between enterprise capital and state capital. Enterprises are not necessary to take any risk of bankruptcy even they have had unsuccessful managements. So the accumulation funds are very easy to be shifted to the consumption funds. All of these lead to the expansions both in investment demand and in consumption demand.

Hence in the light of the special conditions of China, we suggest interest rate be appropriately raised and floated, so as to alleviate the contradiction of supply and demand effectively, the central bank be free from administrative offices of the government instead of subordinate to the macro economic goals, a complete economic system be built up which supports the advanced and punishes the disadvantaged, thus raising the investment profit and then decreasing the inflation.

IV. Price Tests

During the process of price tests, we first maintain the price at a proper level (say, $P=100$). The simulation results show that GNP grows slowly, the deviation between commodity supply and demand becomes more and more big, economic environment tend to be deteriorated. Then we put the price variable under control of MDISC and DISC1 and select appropriate money supply policies. The simulation results this time show that price rises slowly and fluctuates, playing a role of an economic lever.

Actually the price has been frozen for a long time before China's economic system reform, thus the moving orbit of the economic system is blocked up and a potential energy of price rising is tremendously gathered. As a matter of fact, the price rising now in China just indicates that the hidden form inflation is replaced by the obvious form one.

China's economic system is supported in a great way by financial subsidies. This is the main root of the inflation from the conventional economic system. The consumption subsidy leads to urging high consumptions, restraining production and wasting resources. The loss subsidy leads to encouraging low profit and expanding investment demand. All of these intensify the contradiction of the total supply and demand and then promote inflation.

The other root of the inflation comes from the strategical faults in the economic reform of China. The original intention of the economic reform is to promote the productivity by properly enlarging the income differences between individuals and by giving awards to model workers. However now in China things go contrary to the wishes, because the work-force market is not completely formed and the income level is lack of market regulation. In addition, there exist some defects in the double-tracked price system, so that the state of management in enterprises does not objectively reflect the real value. The competition of individual incomes instead of productivity between enterprises becomes more and more intense. Thereby the growth of individual income increases over the growth of productivity. Naturally the price rises rapidly.

To this end we suggest the economic reform now in China be deepened, a long-termed and stable money policy be formulated to make money supply and the development of the economy coordinated, more attention be paid to rising the productivity instead of pursuing the high speed of economic growth alone, thus we can control the total demand and restrain the expansion of the inflation.

V. Conclusion

In general, price is always looked as a lever in commodity market and interest rate as a lever in monetary market. While we find in our work this point of view is one-side. We can see in the flowchart of our model that in the monetary market the regulation of the deviation between money supply and demand depends upon two negative feedback loops. When the money supply keeps constant, on one hand the rise of interest rate may decrease the speculation demand of money, on the other hand the rise of price may increase the transaction demand of money. And in the commodity market interest rate can respectively regulate the deviation between commodity supply and demand through a negative feedback loop. In all, price level and interest rate, the two economic levers, have close links with each other in the whole economic system. We should make sufficient and rational use of their regulative effects.

The inflation now China is faced with results from the defects of both the conventional economic system and the economic reform policies. In order to control the inflation we must comprehensively analysis the special conditions of China and accurately apply the lever effects of price and interest rate to the whole economic system so as to ensuer the stable development of the economic system reform of China.

References

1. Forrester, J. W. 1968. Principles of Systems. Cambridge, The MIT Press, USA.
2. Tomkins, R. 1981. Structural Features of a System Dynamics Model of the UK Economy, SystemDynamics and Analysis of Change. North-Holland Publishing Company.
3. The Statistical Bureau of China, 1987. Statistical Almance of China, The Statistical Press of China, 1988.
4. Xu, Xingfa, 1985, Financial Forecasts, Beijing Institute of Modern Administration, China.
5. Dai, Yuanchen, 1986. Socialist Macroeconomics, Financial and Economical Press, China.
6. Ma, Hong et al. 1981. Studies on the Problems of the Economiuc Structures of China. The People's Press, China.