

THE SPREAD OF '88 SHANGHAI TYPE-A HEPATITIS: A SYSTEM DYNAMICS MODEL AND ANALYSIS

Mao-Kang Su & Huan-Chen Wang
Systems Engineering Institute
Management School
Shanghai Jiao Tong University
Shanghai, 200052, P.R.China

ABSTRACT

In this paper, first of all, a qualitative analysis is done on a general infectious disease SD model, and a new epidemic threshold value and an epidemic scale forecasting formula are proposed. Then in consideration of the properties of type-A hepatitis and its eruptive spread, the '88 Shanghai type-A hepatitis eruptive spread SD model is put forward. A lot of work in various aspects is done, for example: the problem to simulate the type-A hepatitis incubation period is solved practically; the simulation results fitted in with the reality are achieved; through simulation analysis and qualitative analysis, the reason for that the predicted 2nd peak of this spread didn't appear is found out; the short-term and long-term prospects of Shanghai type-A hepatitis situation are brought forward; especially, hypotheses about the mechanisms of the periodic epidemic and the eruptive spread of type-A hepatitis are put forward. These results are imbued with guiding significance for prevention and control of the type-A hepatitis and other infectious diseases.

I. A GENERAL INFECTIOUS DISEASE MODEL (GIDM) AND ITS MOVEMENT TRAJECTORY

Researches about mathematical models of infectious diseases have not been reported in China. American scholars D.G.Luenberger(1979) and G.P.Richarson etc.(1981) brought forward basic models respectively which have a similar structure. British scholars B.C. Dangerfield etc.(1988) proposed a model about the spread of AIDS. No matter how different the concrete occasions and the details are, the principle of these models is the same. The flow diagram of a general infectious disease SD model(GIDM) is shown in Fig. 1. Its equivalent system of 1st-order differential equations is as follows.

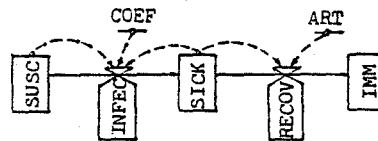

Fig. 1 The Flow Diagram of the GIDM

$$\begin{aligned}
 (\text{SICK}(t))' &= -\text{COEF} \cdot \text{SUSC}(t) \cdot \text{SICK}(t) \\
 (\text{SICK}(t))' &= \text{COEF} \cdot \text{SUSC}(t) \cdot \text{SICK}(t) - \text{SICK}(t)/\text{ART} \\
 (\text{IMM}(t))' &= \text{SICK}(t)/\text{ART}
 \end{aligned}$$

among which SUSC is the susceptible, SICK is the sick, IMM is the immune, INFEC is an infection rate (people/day, see Fig. 1), RECOV is a recovery rate (people/day), COEF is a contagion coefficient, and ART is an average recovery time. Since $(\text{SUSC}(t) + \text{SICK}(t) + \text{IMM}(t))' = 0$, total population TOTP are constant in the model. Because IMM doesn't appear in the first two equations, the problem of this 3rd-order nonlinear system can be studied on a two-dimensional level-level plane from the view point of qualitative theory. The movement trajectory equation of the system can be easily obtained as

$$\text{SICK} = \rho \ln \frac{\text{SUSC}}{\text{SUSC}(0)} - \text{SUSC} + \text{SICK}(0) + \text{SUSC}(0) \quad (1)$$

where $\rho = 1/(\text{COEF} \cdot \text{ART})$. From (1), it can be seen that along a trajectory, $\text{SICK} + \text{SUSC} - \rho \ln(\text{SUSC}) = \text{Constant}$. Several trajectories are illustrated in Fig. 2. It can be proved that the vertical $\text{SUSC} = \rho$ is just crossing the vertexes of the trajectory family. So ρ is a threshold value for the susceptible which decides whether the sick will have their peak in an epidemic process. The threshold value ρ was first put forward by Kermack and McKendrick in 1927.

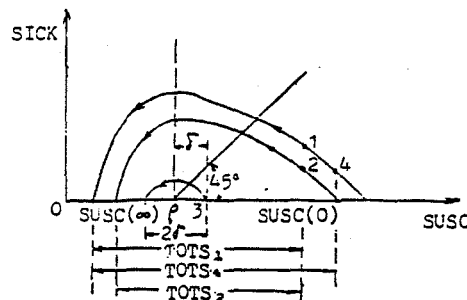

Fig. 2 Movement Trajectories of the GDM & Their Geometric Analysis

II. EFFECTS OF AN INITIAL STATE ON AN EPIDEMIC: A NEW THRESHOLD VALUE ρ , A DIVISION OF THE STATE PLANE, AND AN EPIDEMIC SCALE FORECASTING FORMULA

Effects of an initial state on an epidemic can be divided into two aspects: 1) whether an epidemic will appear, and 2) how large the epidemic scale is. In epidemiology and antiepidemic work, whether an epidemic has appeared is judged by whether curve INFEC has its peak. So it is necessary that a new threshold value corresponding to this situation be introduced. From Fig. 1, we can see that the infection rate

$$\text{INFEC} = \text{COEF} \cdot \text{SUSC} \cdot \text{SICK},$$

so

$$\begin{aligned}
 (\text{INFEC})' &= \text{COEF} \cdot (\text{SUSC})' \cdot \text{SICK} + \text{COEF} \cdot \text{SUSC} \cdot (\text{SICK})' \\
 &= (-\text{COEF} \cdot \text{SICK} + \text{COEF} \cdot \text{SUSC} - 1/\text{ART}) \cdot \text{INFEC},
 \end{aligned}$$

obviously, $(-COEF \cdot SICK + COEF \cdot SUSC - 1/ART)$ is a time-varying growth rate of INFEC. When INFEC reaches its maximum, there holds the equation

$$\begin{aligned} SICK &= SUSC - 1/(COEF \cdot ART) \\ &= SUSC - \rho. \end{aligned}$$

The above equation represents a line which crosses point $(\rho, 0)$, and has a 45° angle with the horizontal axis, as is shown in Fig. 2. It is clear that if a starting point of the state stands on the right-under side of the line, the state will move across the line along the corresponding trajectory, and a positive growth rate of INFEC will become a negative one, so the time trajectory of INFEC must have its peak; if the starting point is on the left-above side of the line, the INFEC will monotonically decrease as time goes on. Therefore, if we set $\phi = SICK(0) + \rho$, then the ϕ is another threshold value for the susceptible which decides whether the INFEC will have its peak in an epidemic. Effects of both ρ and ϕ are apparently summed up in Fig. 3. From this figure, we can see that the state plane is divided into three areas by two lines.

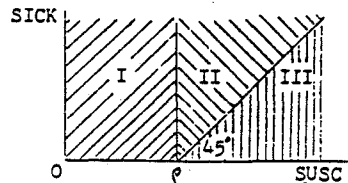

Fig. 3 A Division of the State Plane

starting point of the state is in Area I, both curves SICK and INFEC will monotonically decrease; if it is in Area II, curve SICK will have its peak, but curve INFEC will still decrease monotonically; and if it is in Area III, both curves SICK and INFEC will have their peaks respectively, but the peak time of INFEC will definitely be earlier than that of SICK. Simulation tests of the above conclusion are shown in Fig. 4. Using the movement trajectory equation, an approximate forecasting formula for the epidemic scale, i.e. the total sufferers is put forward as the form (M.K. Su, 1989)

$$TOTS = \frac{\phi + \sqrt{\phi^2 + 2\rho \cdot SICK(0)}}{\rho/SUSC(0)},$$

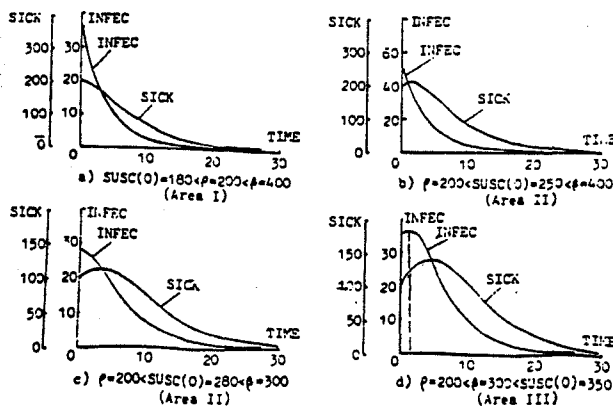

Fig. 4 Simulation Results from Different Starting Points (COEF=.001, ART=5)

where $\delta = \text{SUSC}(0) - \rho$. If $\text{SICK}(0) \ll \delta/2$, and $\rho/\text{SUSC}(0)$ is close to 1, the above formula can be further simplified as

$$\text{TOTS} = 2\delta.$$

It is thus evident that the TOTS is a function of the initial state. Its geometric significance is shown in Fig. 2. From the figure, we can know that when $\text{SUSC}(0)$ is keeping unchanged, the more $\text{SICK}(0)$ is, the larger the TOTS is (Compare point 1 with point 2.); when $\text{SICK}(0)$ is keeping unchanged, the more $\text{SUSC}(0)$ is, i.e. the farther $\text{SUSC}(0)$ is from ρ , the larger the TOTS is (Compare point 2 with point 4.); and when $\text{SICK}(0)$ is close to ρ and nearby the horizontal axis, $\text{SUSC}(0)$ and $\text{SUSC}(\infty)$ are nearly symmetric about ρ . (See point 3.)

III. MODELLING OF '88 SHANGHAI TYPE-A HEPATITIS ERUPTIVE SPREAD

3.1 A General Survey of the Spread and its Characteristics

In mid-January 1988, a type-A hepatitis eruptive spread appeared in Shanghai, China. From mid-January through mid-February the spread reached its high tide. In the end of January, incidence cases per day reached their summit (over 15,000) which was nearly 500 times more than the average level before the spread. In the beginning of February the incidence rate began to decline rapidly, but after the last ten days of February it showed a tendency to ease up, and the incidence rate didn't resume its former level until the first ten days of July. From the first ten days of January through the first ten days of July, the incidence cases totaled 350,631. If we deduct the average incidence cases in the same period of past years, the total number will be 344,901. In short, this spread is of the most serious harm in the history of type-A hepatitis epidemics in the world.

Since the type-A hepatitis is a kind of infectious diseases, the contagion mechanism expressed in the GIDM must have existed in this spread. But it was impossible that only by means of contagion occurred a spread with so large scale in such a short period. Epidemiologic surveys, clinical analyses of disease cases, and blood serum tests proved that this spread was caused by polluted blood clams. Therefore, the characteristics of this spread must be considered in our model: 1) in the spread there were two reasons resulting in type-A hepatitis infections: one was by eating the polluted blood clams, and the other was through contagion; 2) the type-A hepatitis infections can be divided into two types: the dominant and the recessive. Sampling investigations showed that dominant and recessive infection cases were in a ratio of about 3 to 1, but those caused by the contagion were in a ratio of about 1 to 13.17 (Zhi-Hong Guo etc., 1988); 3) the incubation period of type-A hepatitis (averagely 32 days) is a factor not to be ignored; and 4) the infection source in the spread was complicated. The infectivity of the dominantly infected is in the end of the incubation period, and the beginning of the recovery period, mainly in the 5 days before incidence and the 10 days after incidence. Though the recessively infected are symptomless, they have their infectivity in the corresponding period.

The Shanghai Type-A Hepatitis Eruptive Spread Model (STAHESM) reflects the above characteristics and retains the contagion

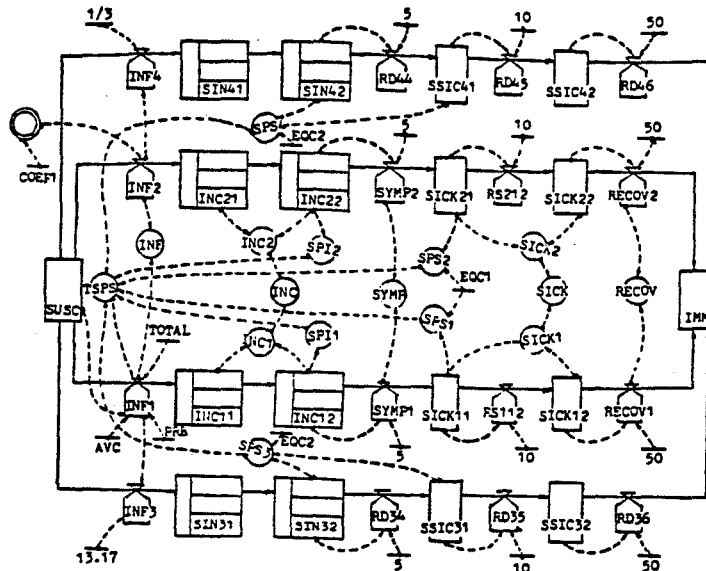

Fig. 5 The Flow Diagram of the '88 Shanghai Type-A Hepatitis Eruptive Spread SD Model

mechanism of the GIDM. Its flow diagram is shown in Fig. 5. From the figure, we can see that the evolution from the susceptible to the immune has 4 paths: path 1 (the dominant path caused by the contagion), path 2 (the dominant path caused by the polluted blood clams), path 3 (the recessive path caused by the contagion), and path 4 (the recessive path caused by the polluted blood clams). If a variable name in the flow diagram includes figure numbers, the first figure represents the path number which the variable stands on, for instance SYMP2, SICK21 etc. In the STAHESM, the incubation period is divided into period I (the earlier 27 days) and period II (the latter 5 days with infectivity), and the recovery period (60 days long averagely) is also divided into period I (the earlier 10 days with infectivity) and period II (the latter 50 days).

3.2 How to Simulate the Incubation Period of the Type-A Hepatitis

As is known to all, using the DELAY function in DYNAMO, we can simulate the incubation period. But how do we determine its parameters? The parameter of average delay time (average incubation period) is about 32 days. It is basically definite because it has been scientifically determined by medical scientists. Therefore, the crux lies in another parameter, i.e. order k . Using the data of 1072 cases in this spread reported by Shanghai Sanitation and Antiepidemic Station, and the following estimation formula (M.S. Hamilton, 1976; Mao-Kang Su, 1989)

$$\hat{k} = \frac{(\overline{DEL})^2}{\frac{\sum n_i \cdot (i - \overline{DEL})^2}{\sum n_i - 1}}$$

we can know that the order is about 28. In the formula \overline{DEL} is an estimated value of the average delay time, n_i is the number of cases with delay time i . From Fig. 6, it can be seen that the reasonable choice of k is one of the key factors to guarantee a successful simulation. In modelling practice, whether the above systematic method should be taken for the choice of k depends on

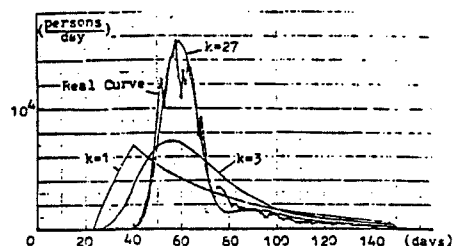

Fig. 6 Sensitivity Tests of Simulated Spread Curve with Respect to Delay Order k

inputs. Generally, if the inputs are continuous, smoothed and changing slowly functions, k is not very important, but if the inputs are discontinuous or changing suddenly functions, such as PULSE, STEP etc., k is usually very important. In this spread, plenty of polluted blood clams on the market in a short time can be seen a pulse-type input in the model.

IV. SIMULATION ANALYSIS AND QUALITATIVE ANALYSIS OF THE STAHESM

4.1 The Simulated Spread Curve of '88 Shanghai Type-A Hepatitis Eruptive Spread

If we set parameter COEF1=1, the factor of the polluted blood clams will be introduced into the STAHESM, and the basic situation of '88 Shanghai type-A hepatitis eruptive spread will be simulated on the model. The spread curve is what the antiepidemic circles are the most interested in. The simulated spread curve and its decomposition are shown in Fig. 7, where SYMP2 is the dominant incidence rate (people/day) caused by the polluted blood clams, SYMP1 is the dominant incidence rate caused by the contagion (including the original level before the spread), and SYMP is the composition of both SYMP2 and SYMP1. From the figure it is obvious that in the earlier stage of the spread SYMP consisted nearly of SYMP2, but in the latter stage it consisted mainly of SYMP1. The abscissa of the intersection point of curves SYMP2 and SYMP1 is 76 (Feb. 14) which is the dividing point of the two stages. When $t > 92$ (March 1), nearly holds the equality: SYMP = SYMP1. This result of simulation analysis about the spread curve tallies with the analysis result of the group stochastic sampling method reported by Shanghai Sanitation and Antiepidemic Station. From Fig. 6 we can see that the simulated spread curve is well fitted in with the real one. Both curves have no apparent 2nd peak. But in the decomposed curve (See curve SYMP1 in Fig. 7.) a 2nd peak still exists. The peak

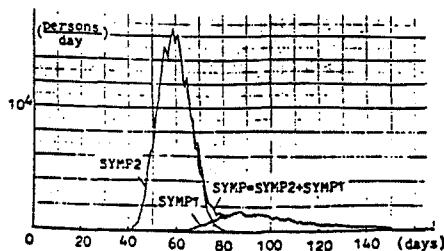

Fig. 7 The Simulated '88 Spread Curve & its Dicomposition

time was in the end of February and the beginning of March, i.e. it occurred behind that of the 1st peak (See curve SYMP2 in Fig. 7.) about 30 days, close to the average incubation period.

4.2 Total Scale and its Composition of This Spread

The simulated curve of the total dominant sufferers from the type-A hepatitis in this spread is shown in Fig. 8, where ACSI2 is the total dominant sufferers caused by the polluted blood clams, ACSI1 is the total dominant sufferers caused by the contagion, and ACSI is the composition of both ACSI2 and ACSI1. From January 1, 1988 through July 9, 1988, the total number of dominant sufferers obtained through simulation are 362,605 cases, among which the total dominant sufferers caused by the polluted blood clams are 280,610, make up 77.4%, and the total dominant sufferers caused by the contagion are 81,995, amount to 22.6%. This is the first estimate of the sufferers' composition in this spread.

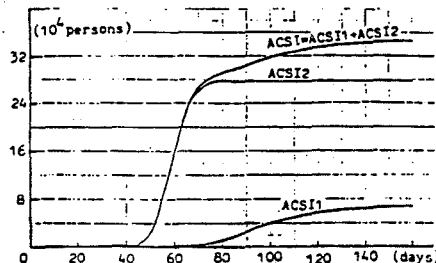

Fig. 8 The Simulated Curves of Total Sufferers & Their Components

4.3 The Spread Scale was Restained by Shanghai Municipality's Prompt Prohibition of Selling the Polluted Blood Clams

Round about New Year's day of 1988, the incidence rate of diarrhoea increased dramatically in Shanghai. Epidemiologic surveys showed that the epidemic of diarrhoea was relevant to the polluted blood clams eaten by the residents. Sharply foreseeing the possibility of the type-A hepatitis eruptive spread, Shanghai Sanitation and Antiepidemic Station reported the situation to the Municipality and demanded a prompt prohibition of selling the polluted blood clams in January 3. The Municipality heads resolutely made a decision of the prohibition in January 4. Just as expected, from January 14, 1988, in the all 12 districts of Shanghai the incidence of the type-A hepatitis increased rapidly at the almost same time. But thanks to the prompt prohibition, the incidence rate began to decrease apparently in the beginning of February. If the Municipality heads had hesitated to make the decision at that time, what would the spread situation have been? This question can be answered through simulations with different prohibition times. For example, Fig. 9 shows the consequences of the prohibition decision put off for only 10 days: an increment of 140,000 cases in the spread scale, equivalent to the area of the shadow part in the figure where prohibition time $ENT = 40$ corresponds to January 4 when the real prohibition order was issued. According to the surveys of Shanghai Sanitation and Antiepidemic Station, 2,000 tons of blood clams sold on the market in the spread came from the coast regions nearby Qi-dong County, Jiangu Province where the

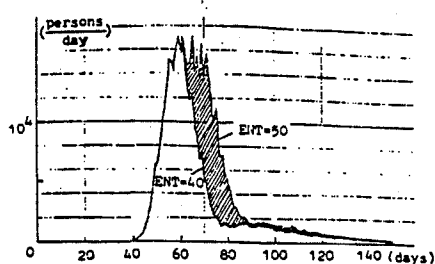

Fig. 9 A Comparison between Two Simulated Spread Curves with Different Prohibition Times

reserves were as huge as 50,000 tons. Obviously, the spread scale would have been larger unless the polluted blood clams had been prohibited from sale.

A sensitivity analysis with regard to the prohibition time proves that it may not necessarily be true that the larger the spread scale is, the longer the duration of the eruptive spread is. The reason for this is that in an eruptive spread, the larger the spread scale is, the less the susceptible become in a short time. Since the susceptible are the prospective objects of the contagion, and in the latter stage of the spread, the contagion nearly plays a sole role, less susceptible enable the duration to shorten.

4.4 The Dynamic Behaviours of the Main Variables in Path 2 (the Dominant Path Caused by the Polluted Blood Clams)

It is very important that we study the dynamic behaviours of main variables separately according to their paths in order to recognize the mechanism of the type-A hepatitis eruptive spread and analyse the intrinsic relations and the mutual effects among the variables in the spread process. The simulated dynamic behaviours of the main variables in path 2 are illustrated in Fig. 10. In the

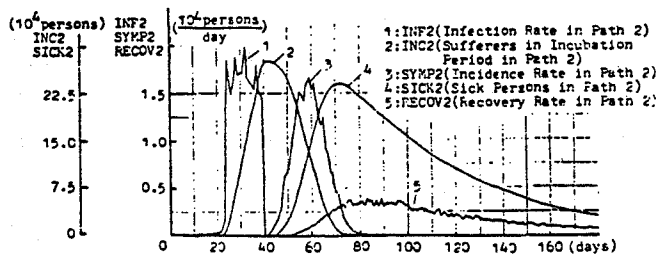

Fig. 10 The Simulated Dynamic Behaviours of the Main Variables in Path 2

figure between the two peaks of curve 1 and curve 3 there exists an interval close to the average incubation period of the type-A hepatitis. It is evident that the system was shocked by a pulse (i.e. plenty of polluted blood clams sold on the market in a short time) which resulted in the spread. Since the system was quasi-stable, and of the ability of antidisturbance, as time went on, the main variables gradually restored their normal states. We should pay attention to the time series of the chain reaction in the path. Due to the last time constant in path 2 (the average recovery period) is as long as 60 days, up to the 180th day, SICK2 and RECOV2 didn't restore their original levels.

4.5 The Dynamic Behaviours of the Main Variables in Path 1 (the Dominant Path Caused by the Contagion)

The simulated dynamic behaviours of the main variables in path 1 are shown in Fig. 11. Comparing Fig. 11 with Fig. 10, we can find that the peak of INF1 (infection rate in path 1) is exactly corresponding to the peak of SYMP2 (incidence rate in path 2) at the time abscissa. This clearly shows that the rising and falling of the variables in path 1 which originally were calm was caused by the upsurge of the incidence in path 2 (as well as path 4). If we had

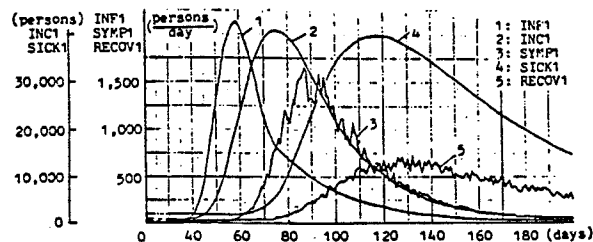

Fig. 11 The Simulated Dynamic Behaviours of the Main Variables in Path 1

gotten rid of the factor of the polluted blood clams (by setting $COEF1 = 0$), the above variables in path 2 would have been zeros permanently, and the situation in path 1 would have been another scene reflecting the normal incidence before this spread, as shown in Fig. 12.

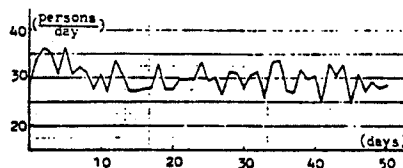

Fig. 12 The Simulated Normal Incidence Curve before this Spread

On the basis of simulation analysis, a very convincing conclusion about the mechanism of this type-A hepatitis eruptive spread can be obtained:

THE '88 SHANGHAI TYPE-A HEPATITIS ERUPTIVE SPREAD WAS CAUSED BY PLENTY OF POLLUTED BLOOD CLAMS SOLD ON THE MARKET, AND WAS STILL ACCOMPANIED BY THE CONTAGION MECHANISM. IT WAS A COMPLICATED PROCESS GUIDED BY THESE TWO FACTORS.

It should be paid attention to that INF1 was rapidly decreasing along with the decline of SYMP2, but due to the upsurge of the incidence in path 1 (as well as path 3) which was another reason stimulating the contagion, the decrease tendency of INF1 was relaxed. The chain reaction in path 1 had the same time series as that in path 2, but the changes of the variables in path 1 occurred behind that of the corresponding variables in path 2.

4.6 Why There Wasn't a 2nd Peak in the Spread Curve?

It was forecasted in the press that in the beginning of March, 1988 a 2nd peak would appear in this spread. The news was of course paid a good deal of attention to by all sections of the people. But it didn't occur in fact. The simulated dynamic behaviours of the variables composed of the corresponding variables in path 1 and path 2 are shown in Fig. 13. In the figure curve 1 has its 2nd peak obviously, but curve 3, i.e. the spread curve, has no distinct 2nd peak. This just tallies with the following theorem about System Dynamics delays (Mao-Kang Su, 1989):

THEOREM. A SYSTEM DYNAMICS DELAY HAS AN ABILITY TO RESTAIN A PULSE, EXCEPT THE SITUATION WHEN ITS ORDER k IS INFINITE. GIVEN THE ORDER OF THE DELAY, THE LONGER THE AVERAGE DELAY TIME IS, THE STRONGER THE ABILITY IS.

The belief that a 2nd peak in the infection curve INF will inevitably result in a 2nd peak in the spread curve SYMP in fact is based on misunderstanding, i.e. taking the incubation period (the distributed delay) as the pure delay (the infinite-order delay). In a type-A hepatitis eruptive spread caused by food source, there may not necessarily exist a 2nd peak of incidence. Whether or not it appears is dependent on the distribution of the polluted food amount sold on the market, and the virus density contained in the food.

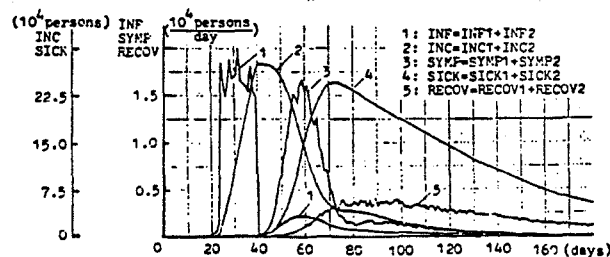

Fig. 13 The Simulated Dynamic Behaviours of the Variables Composed the Corresponding Variables in Path 1 and Path 2

4.7 When Could the Effect of the Spread be Basically Eliminated?

It is a common view that when the incidence rate SYMP returns to its original level, the effect of the spread is basically eliminated. But as we know, SYMP is just the middle variable in the path composed of path 1 and path 2, and the rising and falling of the variables in the path is successive. So only when RECOV, i.e. the last variable in the path, returns to its normal level, can the effect of the spread be basically removed. The simulation showed that it would take 11 months for the effect of the spread to be basically eliminated.

4.8 The Shanghai Type-A Hepatitis Epidemic Situation in Short-term Prospect

Since all variables in the 4 paths return to their normal levels, why do we still say that the effect of the spread is eliminated only basically but not completely? The reason for this is that states SUSC (the susceptible) and IMM (the immune) could not be restored. This result has a rather profound effect on the Shanghai

type-A hepatitis epidemic situation. The simulated curves SUSC and IMM are shown in Fig. 14. In this spread, about 1,300,000

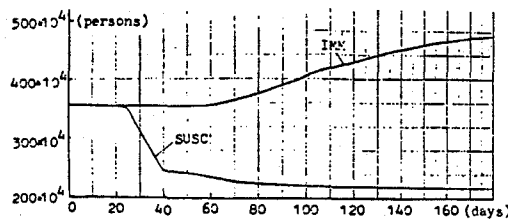

Fig. 14 The Simulated Curves of SUSC & IMM in the '88 Eruptive Spread

susceptible persons became immune persons through the dominant and recessive paths, with the result that the susceptible greatly decreased in number. So in the short run, the incidence rate will not only return to its original level, but also decrease to a certain extent. The simulations demonstrated that the incidence rate after the spread would decrease to 20 - 26 (persons/day). According to the data of Shanghai Sanitation and Antiepidemic Station, the average incidence rate in July, August and September, 1988 was 27.4, 20 and 20 respectively. Thus it can be seen that both the theoretical inference and the simulation result coincide with the fact.

4.9 A Hypothesis about the Mechanism of the Type-A Hepatitis Periodic Epidemics

From the view point of qualitative theory, we propose an explanation for the mechanisms of both the periodic epidemics and the eruptive spread of type-A hepatitis, and get an exceptional insight. If we aggregate the 4 paths in the STAHESM as one path, and aggregate the sufferers in both the incubation period and the recovery period as one state (state SICK), we can do further analysis of the type-A hepatitis epidemics by using the qualitative conclusions of the GIDM.

In view of the normal incidence, we can know that state SUSC is definitely less than ρ ($\neq \rho$, because SICK is small), and state SICK is very close to the abscissa due to its lower level. Therefore, we can assume that the starting point is at A (See Fig. 15.). Theoretically, the state SICK should have been at the abscissa, but in the city which has a population of more than 7,000,000, it is natural that a few people are infected with type-A hepatitis every day through polluted water and food, or through contagion. Owing to that an epidemic process generally ends within several months, we have not considered the change of the total population

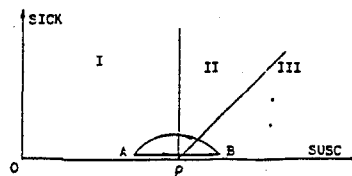

Fig. 15 A Geometric Explanation about the Periodic Epidemics of Type-A Hepatitis

in both the GIDM and the STAHESM in order to simplify the problem. But in the long run, the change of the total population has an important effect on the type-A hepatitis epidemic situation. In recent years, in the urban district of Shanghai, the annual incidence cases of hepatitis totaled about 10,000, among which that of type-A made up less than 50%, and the natural yearly increment of population was about 70,000. Because of that newborns are almost all susceptible, and the dead of old age should mostly have been immune, the susceptible will increase in number annually. Things stand like that especially in the 1950s and 1960s, because the family planning policy hadn't been put forward, the natural growth rate of population was much higher. With the lapse of time, when SUSC reaches a certain level which is greater than the threshold value β , i.e. the state enters into Area III, for example it reaches at point B, a natural epidemic will certainly occur, i.e. the state will quickly move along its movement trajectory from B to A. (It may not necessarily reach at A exactly. The treatment here is just for simplification. The situation of B can be on the analogy of this.) Generally, the duration of an epidemic is only several months. But it commonly takes 5-7 years for the state to move from A to B. Things will go around and begin again in this way. This is the basic reason for that there existed a 5-7 periodicity in Shanghai type-A hepatitis natural epidemics, provided no eruptive spread occurred. (See the Fig. 16.) Since the susceptible has dropped extraordinarily after this spread, it is estimated that the next natural periodic epidemic will be considerably postponed. This is a long-term prospect for the Shanghai type-A hepatitis epidemic situation. (cf. the conclusions in 4.10)

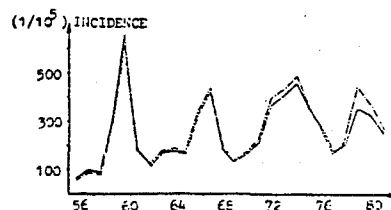

Fig. 16 The General & Standardized Incidences of Acute Hepatitis in 1956-1980 in Shanghai

Besides, we should pay attention to the two factors of family planning and lengthening of average life expectancy which also have effects on the periodic epidemics. Some people doubt that the threshold value ρ is relevant to the susceptible, rather than their proportion. In fact, the factor of total population TOTP has been included in parameter COEF in form of

$$\text{COEF} = \text{PR} \cdot \text{AVC} / \text{TOTP},$$

where AVC is an average number of contacts per sick person in unit time, and PR is the probability that a contact results in infection. Therefore, we have

$$\begin{aligned} \rho &= 1 / (\text{COEF} \cdot \text{ART}) \\ &= \text{TOTP} / (\text{PR} \cdot \text{AVC} \cdot \text{ART}). \end{aligned}$$

Obviously, the relation between SUSC and ρ is equivalent to the relation between susceptible proportion SUSC/TOTP and constant

$1/(PR \cdot AVC \cdot ART)$. If the family planning policy is put into good practice and the average life expectancy is raised continuously, the susceptible will grow slowly, even negatively, and the immune proportion will tend to become larger. According to the above equivalent relation, these two factors will be advantageous to the restraint of the natural periodic epidemics of type-A hepatitis.

4.10 A Hypothesis about the Mechanism of Type-A Hepatitis Eruptive Spread

As stated above, when the system is under normal conditions, we can assume that the state is at A, as shown in Fig. 17. With the passage of time, the state will move towards B slowly. If it smoothly reaches at B, a natural periodic epidemic will occur. But, if when the moving is in progress, for example, the state just goes through C, the system is shocked by a pulse, such as plenty of polluted blood clams sold on the market in a short time, an eruptive spread will appear. The reason for this is that the pulse erable large

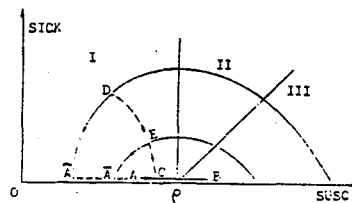

Fig. 17 A Geometric Explanation about the Eruptive Spread of Type-A Hepatitis

numbers of the susceptible to be infected in very short time, for instance ten odd days, (See curve SUSC in Fig. 14.) thus the state of the system change from C to D considerably and suddenly, afterwards the state will move along the corresponding trajectory towards \bar{A} . That proves that the quick movement of the state from C to D in the earlier stage of the eruptive spread is triggered by the external factor, but the movement from D to \bar{A} is mainly guided by the contagion mechanism. This result from qualitative analysis is entirely consistent with the result from simulation analysis. (See the Fig. 7 and the conclusion in Section 4.5.) It is clear that the weaker the intensity of the pulse is, the smaller the scale of eruptive spread is. A smaller and a larger spreads are respectively illustrated as C-E- \bar{A} and C-D- \bar{A} in Fig. 17. In Shanghai the eruptive spread which occurred in the end of 1982 and the beginning of 1983 was only 3 years away from the last natural periodic epidemic in 1979. Judging by this, we can know that the spread was triggered by an external factor when the moving of the state from A towards B was in progress. Due to its smaller scale, there is no harm in assuming that its movement trajectory is C-E- \bar{A} . After 5 years' interval, in the beginning of 1988 a new eruptive spread occurred in Shanghai. It is quite evident that the spread was caused by the similar factor in the movement process of the state from A towards B. Because of its larger scale, we might as well assume that its movement trajectory is C-D- \bar{A} . (Here C may not necessarily be exactly equal to the C in C-E- \bar{A} . It is just a sketchy representation.) Comparing the two movement trajectories in Fig. 17, we can reach the following conclusion:

AN ERUPTIVE SPREAD WILL ENABLE THE NEXT NATURAL PERIODIC EPIDEMIC TO BE POSTPONED. THE LARGER THE SCALE OF THE ERUPTIVE SPREAD IS, THE LATTER THE NEXT NATURAL PERIODIC EPIDEMIC WILL BE POSTPONED.

It is a good example that the last natural periodic epidemic appeared in 1979, i.e. 10 years ago. But we should attach great importance to another conclusion:

AN ERUPTIVE SPREAD DOESN'T GUARANTEE THAT ANOTHER ERUPTIVE SPREAD WILL NOT OCCUR IN THE NEAR FUTURE.

It is a case in point that within the last 10 years the two eruptive spreads have appeared one after another. Why does it have so different effects? Because the periodic epidemic and the eruptive spread have different mechanisms. The former is caused mainly by the contagion when the susceptible exceed the threshold value ϕ , i.e. the state enters Area III, but the latter may be triggered by the external factors, such as polluted water or food, even when the susceptible are less than ϕ , i.e. the state still stands on Area I. In the USA, from 1971 to 1974, there occurred eruptive spreads of the type-A hepatitis 13 times due to polluted water. Since 1955, in the USA, the UK, Sweden, Italy, Japan, Singapore and many African countries eruptive spreads appeared one after another owing to eating polluted shellfishes, such as clams, mussels and oysters etc. In China, the '88 Shanghai spread is the 3rd eruptive spread of the type-A hepatitis caused by eating polluted blood clams since 1977.

It is of great importance for the antiepidemic work of the type-A hepatitis in the future that we sum up experiences and draw lessons, and find out the mechanisms, conditions and regularities of both the periodic epidemic and the eruptive spread of the type-A hepatitis.

APPENDIX

A Table for the Contrast
between Simulation Time and Real Time

Sim. Time	1	...	32	...	63	...	92	...	123	...	153	...	184	...	214	...	235
Real Time	Dec.1 '87	...	Jan.1 '88	...	Feb.1 '88	...	Mar.1 '88	...	Apr.1 '88	...	May 1 '88	...	Jun.1 '88	...	Jul.1 '88	...	Aug.1 '88

REFERENCES

Luenberger, D.G., Introduction to Dynamic Systems, John Wiley & sons, 1979.

G.P.Richarson et al., Introduction to System Dynamics Modeling with DYNAMO, MIT Press, Cambridge, MA, 1981.

B.C.Dangerfield and C.A.Roberts, A Model for Exploring Scenarios Surrounding the Spread of AIDS in the U.K., Proceeding of the 1988 International SD Conference, PF39-52, 1988.

Mao-Kang Su, A Research on Delays, Sensitivity Analysis, & Qualitative Analysis in SD & its Applications in '88 Shanghai Type-A Hepatitis Eruptive Spread SD Model, Ph.D. Dissertation of Shanghai Jiao Tong University, 1989.

Zhi-Hong Guo etc. (Zhejiang Provincial Sanitation and Antiepidemic Station), A Research on the recessive Infection of People in the Epidemic Region of Type-A Hepatitis, Submitted to a China National Antiepidemic Internal Conference, 1988.

M.S. Hamilton, Estimating Lengths and Orders of Delays in System Dynamics Models, Elements of the System Dynamics Method, PF162-182, MIT Press, Cambridge, MA, 1980.