

The Application of a Dynamic Methodology to Assess the Benefit of a Battlefield Information System

By

Simon M Henderson

Royal Armament Research and Development Establishment, United Kingdom

And

Eric F Wolstenholme

Bradford University, United Kingdom

Abstract

This paper describes the application of the system dynamics method to the study of a conceptual military Command, Control, Communications and Information System (CIS) in the early phases of procurement. The work from which this paper was drawn constitutes one half of two parallel study streams to investigate the usefulness of the system dynamics technique in this area (the work did not attempt to assess the CIS itself). The conclusions from both streams are discussed in a separate paper (Gavine, 1990).

The Problem

Within the MOD, it is usually necessary to identify the expected operational benefits and drawbacks of a proposed Command, Control, Communications and Information System (CIS) in the very early stages of procurement. This analysis is often required *before* the pre-feasibility study, when the system is only a concept. At this stage:

- The precise scope and nature of the CIS has yet to be determined.
- No designs for the CIS exist.
- No operational data exists.
- No guide as to the magnitude of CIS effects exists.

This intangibility naturally introduces problems in assessing the system!

Usually, the only tangible information which is available to the analyst at this point is a 'laundry list' of required features which has been produced by a military client.

Objectives of Study

Clearly, there is little use in predicting the future performance of a system, when the current system is not understood - the investigator is unable to relate the predicted output to any form of baseline understanding, thus the prediction is effectively meaningless. It is the process of *structuring* and *analysing* a problem which leads to deeper *understanding*, and eventually *insights*. System Dynamics is able to contribute towards this process through the 'softer', qualitative aspects of the method. To this end, this study was concerned with:

- Structuring the problem through influence diagrams.
- The *representation* (not explicit modelling) of battlefield functions.
- The inclusion of 'fuzzy' or 'hazy' data concerning the CIS.
- The study of broad behavioural dynamics produced by executable models (rather than mathematical prediction)
- Increasing understanding and gaining insights into the CIS.

The CIS Studied

In order to assess the application of system dynamics to the study of CIS in the very early phases of procurement, a *conceptual* tactical system was proposed which would provide facilities at the Battlegroup level and below. Its purpose would be to improve the present command and control process, thereby giving commanders and staff more time for decision making based on accurate, relevant and timely information. A typical list of required attributes relating to this system might consist of the following:

- Automation of a digital map, tied in with a navigational aid (Navaid).
- Improved fire control via the communication of enemy locations between Armoured Fighting Vehicles (AFVs).
- Reduction in the number of overkills through improved allocation of resources, and identification / communication of dead target data.
- Automated secure communications management.
- Automated Nuclear, Biological and Chemical (NBC) and enemy threat alarm and transmission.
- Built In Test Equipment (BITE).
- An up to date measurement of ammunition levels (and their subsequent transmission to other units).
- Transmission of vehicle system status.

Thus the system would enhance the command and control of the Battle Group at all levels by supporting the fast, secure and often automatic exchange of information, both tactical and logistic.

The Approach

Knowledge Acquisition Through Influence Diagramming

Because no designs for the proposed system exists at this stage, a crucial requirement on the part of the analyst is to obtain as much knowledge about the system as possible. This involves discussion with the actors who have a stated interest in the system (these may be individuals or military agencies) each of whom has their own perspective of the situation, and their own views as to facilities and scope of the CIS under consideration.

Influence diagrams were used heavily in this context, and were employed in a 'soft' manner in order to increase understanding, and to help structure the problem. The objectives of using influence diagrams were:

- To provide a mechanism by which military officers can express their thoughts concerning a system, without being distracted by analytical technicalities. Of particular concern is the capture of the perceived environment in which the CIS will exist.
- To identify areas of commonality in the views expressed by the actors involved.
- To highlight contentious views (between actors) as to the nature of systemic interdependencies.
- Ultimately, to obtain a consensus view of the CIS, and the scope of its operation.

It was found that military officers were particularly enthusiastic towards the use of influence diagrams in capturing and structuring their thoughts:

- They felt that the technique enabled a high level, aggregate view of the situation (i.e. the environment in which the CIS would operate) to be represented. The technique was able to capture 'The Big Picture'.
- Officers were able to grasp quickly the techniques which were being used. They were thus able to comprehend easily what was being discussed.
- Officers were not only enthusiastic towards these techniques - they were proactive. On several occasions officers started producing their own influence diagrams, having first contributed ideas to an influence diagram on a white-board, and seen how easily they could be incorporated.

The high level of client involvement in the construction of the influence diagrams resulted in:

- Attention being held.
- Enthusiasm to contribute ideas.
- Credibility in the model.

The influence diagram which was eventually produced through the iterative process of client discussion, debate and diagram refinement is reproduced on the next page (the ovals represent the influences brought about through the introduction of the CIS). The diagram embodies a number of aggregated functional concepts associated with the battlefield environment (i.e. the Battlegroup). Battlefield concepts represented include:

- Weapon Selection (i.e. a commander allocating his available arms)
- Reinforcement
- Logistics
- Target Location
- Target Acquisition and Engagement
- Target Tracking and Coordination
- Weapon Fire
- Movement (in particular, 'shoot and scoot' for a defensive scenario)
- Vehicle Repair
- Secure Communications (Digital Encryption)

Mode of Representation of Battlegroup Functions - An Annotation of the BGM Influence Diagram

This section annotates the BGM influence diagram, and describes the concepts and principles behind each functional representation. However, since all development work was performed using STELLA, it is the flow diagrams which show the current state of the model. Areas where moderate discrepancies arise are noted in the text.

Blue Available Units - The stock of Blue Units represents the aggregation of all generic fighting 'units' belonging to Blue, which are available for combat.

Units can be removed from this stock by three processes:

- i. Breakdown
- ii. Attrition
- iii. Units Hiding

Units can be fed into the stock by three processes:

- i. Reinforcement
- ii. Repair
- iii. Units Repositioning.

Blue starts the scenario with 100 units available.

Blue Hide and Reposition -The Blue Hide and Reposition function represents the movement of units which attempt to conceal their position after firing off a given number of rounds (this is known colloquially as 'shoot and scoot'). Effectively, units are temporarily taken out of the system, where they are unable to be used by Blue for engagement.

Blue Breakdown

The Blue Breakdown function represents the process of units being unable to fight through damage. Again, a loop takes units out of the system, where they remain until they can be repaired. The breakdown loop is very similar to the reposition loop, and uses a 'repair time' and rate to put units back into the 'available' state.

Blue Reinforcement -The Blue Reinforcement function represents the allocation of reserves to the Blue available units.

Blue Target Handling - The target handling function represents the observation (location) of targets, the acquisition of those targets by free Blue units, and the tracking and coordination of these units between the Blue units (Target Destruction is handled under Blue Fire).

Target Location - Target location is traditionally very difficult to model, and usually takes into account terrain, range, geographic dispersal of own and enemy units, weather, obstacles etc. Cross-observation also poses a large problem (i.e. a Blue force of 10 units is located 3km away from a Red force of 30 units. How many Red units can Blue see? Can one Blue unit see many Red Units? Can one Blue unit see all Red units? Can two or more Blue units see one Red unit? etc). A very simplistic observation mechanism was produced through the summation of the two force sizes multiplied by an observation factor.

Target Acquisition - Once targets have been observed, Blue attempts to acquire them with his free units (i.e. the Blue force pairs targets with its own units). This is simply a smoothing function based on a time-to-acquire, which also ensures that Blue does not acquire more targets than he has units available.

Target Coordination and Tracking - In order to represent target loss (i.e. due to targets becoming no longer visible, moving out of an arc of responsibility, getting out of range or simply because Blue is overloaded) a target 'decay' function has been introduced. This reverts enemy units from both the observed, and the acquired state, back into the unobserved state. The rate of decay is governed both by range (i.e. the greater the range, the more chance there is of losing a target) which is handled through a decay factor (or decay proportion); and also by the efficacy of Blue's target handling procedure. It was also necessary for the Acquired_Target_Decay rate to take into account the Blue attrition. This meant that the destruction of units holding acquired targets resulted in the acquired targets being 'released' back into the unobserved state.

Blue Fire - Once some targets have been acquired, they will be fired upon in an attempt to destroy them. The number of units firing is a simple min function of available units and targets acquired (note: although targets and units were matched up in order for the acquisition to take place, this min selection must still be conducted)

Because Blue is using a generic weapon type, all units fire the same number of rounds per DT (note the provision in the influence diagram for the selection of weapon types, and also for the fire rate to be modified by range. These are not, however, currently represented in the flow diagram or model itself). Rounds are then depleted from the stock of available ammunition (note that Blue has an unlimited supply of ammunition in the flow diagram, and thus there is no representative stock).

Red attrition is calculated as the firing rate * productivity_of_fire. The productivity_of_fire is a function of the single shot kill probability (SSKP) for the given range, modified by the accuracy with which Blue is able to locate and follow the targets as they move (in effect, it is simply a compound SSKP).

Once a number of the Red targets have been destroyed, Blue makes an appreciation of the number of kills, represented by the perceived_Red_attr. This perception takes into account observation errors due to range, and also Blue's ability to maintain an accurate picture of the situation (this obtained through visual appreciation, communications and map interpretation).

It is the perceived attrition which is used to remove units from the transformation chain, thus the perceived attrition depletes units from the targets_acquired stock. This means that if Blue has a poor quality picture of the situation, it will leave some attrited targets in the acquired state. This will result in units re-firing at those dead targets, thereby incurring overkill penalties.

Red Representation - Red provides a very simplistic driving function for Blue, which is representative of Red's ability to:

- Advance using ratio policies
- Fire at, and kill, Blue units
- Fire at, and damage, Blue units
- Have its own units kill by Blue fire

Red's advance rate is governed by its perceived superiority in force strength over Blue. This is calculated as a ratio of perceived Red size to perceived Blue size. Red's perception is based on the ability to obtain, process and interpret force size intelligence, and is represented through the accuracy_of_perception parameters. This information could be gained through visual appreciation, observational communication, interception of Blue communication, map analysis etc. It should be noted Red's perception of its

own size uses a perception modifier on the summation of its three unit states (this can be seen more clearly in the flow diagram).

When Red maintains a 3:1 advantage over Blue it will advance at the maximum possible rate. As the ratio drops, Red proportionally slows until the point where Blue gains the advantage, whereupon Red's advance rate becomes negative, thus instigating a withdrawal. It should be noted that the Red advance rate is averaged over time. A more realistic representation would involve modelling the ability of Red to move in short surges. The maximum Red advance rate may therefore appear rather small (100m/min, 6km/hr).

Red calculates the number of Blue targets using a similar method to that of Blue, and making use of a slightly lower productivity of observation (note that Red makes direct use of the number of units to fire at, and does incorporate it as part of a state transformation). This aspect is not entirely clear from the influence diagram, and is seen more clearly in the flow diagram.

Blue attrition is calculated in a similar manner to Blue through the use of a `productivity_of_fire` function. At this point, a certain proportion of the attrited units are treated as damaged, and are thus used in the breakdown/repair cycle. The others are removed from the `Blue_available_units` stock.

Model Construction

Once the influence diagram had been produced, military officers were asked to provide some 'ball-park' figures for some of the relationships expressed in the diagram. It was stressed that the study was concerned with increasing understanding through the study of broad behavioural dynamics. Thus mathematical accuracy was not a primary concern. Throughout the construction of the model more meetings were held with military officers to discuss any problems which were encountered, and to investigate new ideas as they were generated.

The influence diagram was coded in STELLA in order to exploit the graphical user interface for both timeliness of model construction, and also as a form of self-documentation. The STELLA flow diagram is shown on the next pages.

Provision was made in the model for the imposition of CIS attributes, both individually and in union. This was achieved through the use of switches which mapped CIS effects onto key parameters in the associated Battlegroup functions (see Wolstenholme et al, 1990) and can be seen in the various clusters of variables suffixed with 'CUR' (representing the current value) 'CIS' (representing the value with CIS) and 'CIS_Global_Sw' (the 'in-union' switch).

A simplistic scenario was devised in which a Red force of 300 units advances on a Blue force of 100 units from a range of 6000m. The Red advance rate is proportional to the force size ratio, and can be negative to indicate withdrawal. Both Red and Blue operate to a 5km phase line where both visual appreciation and weapon accuracy become effective.

Model Runs and Output

Because STELLA has the ability to plot the behaviour of any variable contained within the model, it is possible to select any as a measure. However, careful selection of variables which show the dynamics of functional interaction can lead to useful insights.

A key objective of this study has been to obtain a mechanism for relating stated CIS attributes to real-world, high level measures (this problem pervades all CIS assessment). Within the model it is possible to study the effects of introducing CIS through analysis of measures such as: attrition rates, target acquisition rates, target overkills, ammunition expended, time to defeat etc.

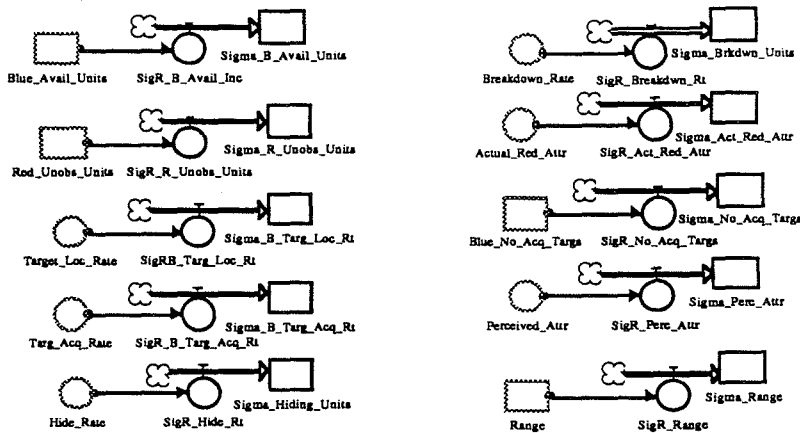
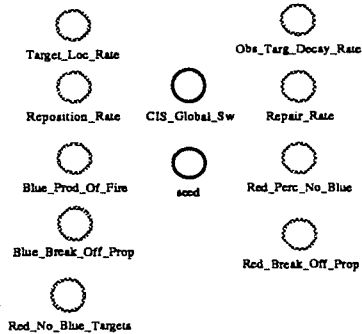
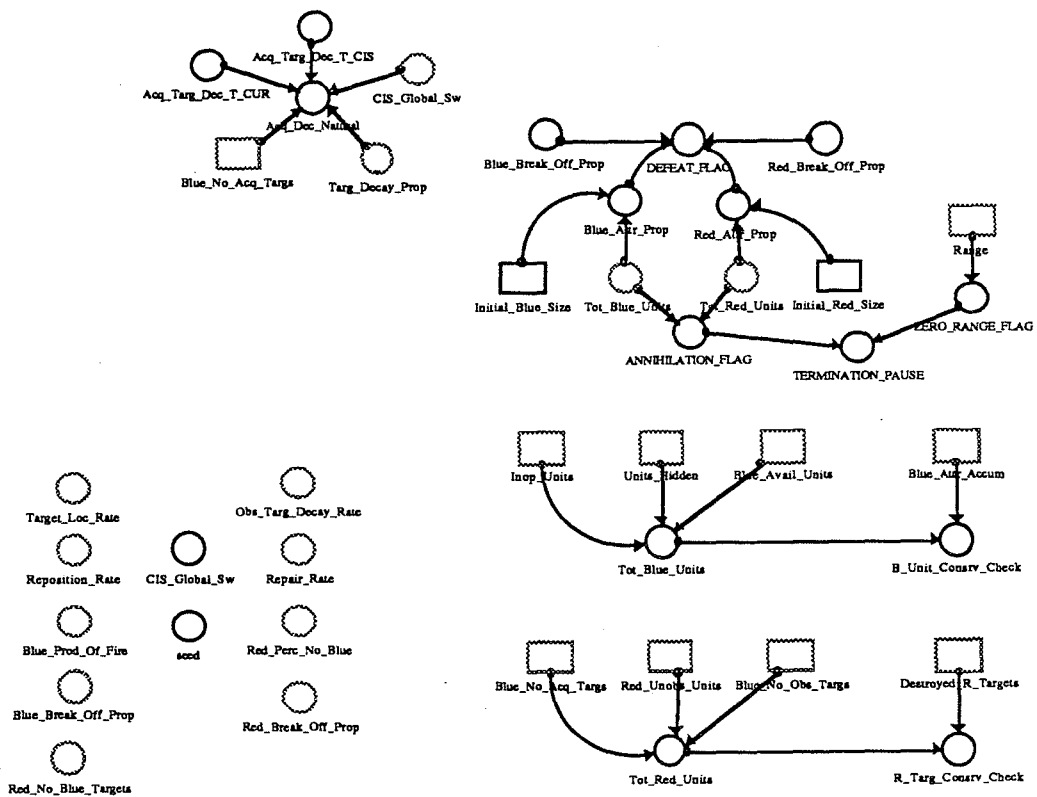

What is also interesting to observe is the accumulative availability of various resources. Because a level may rise and fall many times over the course of a run, it is sometimes difficult to draw conclusions about the level's availability. However, if the level is added to an accumulator at each time step, then it is possible to observe the total availability of that resource over the course of the entire run (it is therefore possible to obtain measures which are similar in concept to 'man-hours'). This is shown in the output plots as 'Sigma' measures (note the range of sigma measures in the flow diagram). Examples of sigma measures are the Sigma Blue_Available_Units and the Sigma_Ammo_Expended.

Each page contains two graphs. The top graph displays the dynamics of certain variables for the baseline run. The bottom graph shows the dynamics of the same variables with all the CIS attributes in effect. Also attached are interpretations of the results, based on knowledge of the effects represented in the model, and obtained through the cross-analysis of the graphs produced.

Some Insights into the CIS Arising from the Study

This section describes some of the insights into the proposed conceptual CIS which have arisen throughout the course of the study, and in particular through cross examination of the model output. It is intended to demonstrate how some of the softer elements of the system dynamics technique could be applied to the study of CIS in general. However, as the objective of this study has been to assess system dynamics (and not this proposed conceptual CIS) a detailed analysis in this area has not been conducted.

Insights are gained throughout the course of the entire study - from initial discussions with clients, right through to the analysis of the behavioural dynamics produced by the model. The insights which are described have arisen mainly during the modelling stages. The processes through which they were highlighted are described, together with the implications for such a CIS.

In a system like this, which supports automated target handoff and management (with the stated objective of reducing overkill) problems might occur when assigning targets to, and removing targets from the target array. Consider the following series of events:

- A Red force advances on Blue.
- Each Blue unit which can see Red targets proceeds to acquire them, with the CIS taking care of multiple allocation problems between units.
- If one Blue unit is then killed, what happens to its targets? Is the CIS aware that the Blue unit has been killed and that its targets are now unassigned? Are the targets still logged as acquired? Is the CIS able to allocate the targets to other Blue units? etc.

This aspect of target allocation was highlighted through the observation of an unexpected dynamic in one early version of the model. It was found that when Blue units were killed, the target array remained full. It was clear that a link between Blue attrition and targets_acquired was missing. Whilst this link is perhaps obvious with hindsight, it was the process of model testing which revealed the omission. This led to consideration of how the real CIS system would cope with Blue attrition (within the context of target management).

A similar problem might occur when Red withdraws. If a Red target has been assigned to a Blue unit, and that target subsequently withdraws out of range (or sight) will the CIS be aware of this fact and remove the target from the array? This problem was again highlighted through the model testing process, where Blue continued to fire at Red targets which were no longer in range simply because they were present in the target array. The problem was resolved through the inclusion of a target 'decay' function.

It would appear to be important that Blue is able to take advantage of the improved availability of units - i.e. it must be able to handle the increase in available targets through better acquisition capabilities. The model showed that when Blue re-positioned more quickly (thereby having more units available to acquire targets with) it actually underwent more attrition. It was found that a link was missing between the number of

Blue units and the rate of target acquisition. This resulted in Blue acquiring the same number of targets, whatever its size, whilst actually leaving more of its own units vulnerable to Red attack. Thus the Blue attrition rate was higher.

Similarly, will the digital mapping and terrain analysis facilities within the CIS enable the Blue force to situate itself on tactically advantageous ground, thereby enabling the observation and acquisition of more targets? Again, will the CIS be able to handle this increase in target availability?

During the fire/move cycle, will the CIS be able to re-allocate targets belonging to units which have moved in order not to disclose their position through flash/Infra Red signatures? Within the model it is assumed that targets are dynamically allocated to other units which become available. Is this possible with the CIS?

An interesting aspect of insight generation is that the structures which give rise to them are often generic. For example, the problems associated with the allocation of targets could easily be applied to the allocation of logistics. If the CIS automatically sends a low ammunition level report to a commander or a logistics coordination point, what happens when the unit generating the report is killed. Does the CIS register this fact, and somehow cancel this report. Whilst over-ordering is unlikely to be seriously affected by the attrition of one unit, the problem becomes more significant when aggregated across the entire battlegroup. Consideration of generic structures and procedures is a way of generating further, non-obvious insights.

Conclusions

The overall conclusions of the study of the application of the System Dynamics technique to the operational evaluation of CIS at the pre-feasibility stage of project implementation are:

- the SD method provides an excellent medium for elicitation of information, problem formulation, and system model design;
- existing SD tools greatly facilitate interaction with the User and the design and implementation of qualitative and quantitative models that address levels, rates and trends;
- changes to the models to reflect alternative procedures or CIS facilities can be readily implemented;
- the very detailed representation of explicit physical and information flows can be difficult or impossible with current tools.

References

Gavine A G, Wolstenholme E F, An Appraisal of System Dynamics in Assessing the Impact of Computer Information Systems, International System Dynamics Conference Paper, Boston, 1990.

Wolstenholme E F, Gavine A W, Watts K M, Henderson S M, The Design of a Dynamics Methodology for the Assessment of Information Systems, International System Dynamics Conference Paper, Boston, 1990.

1a

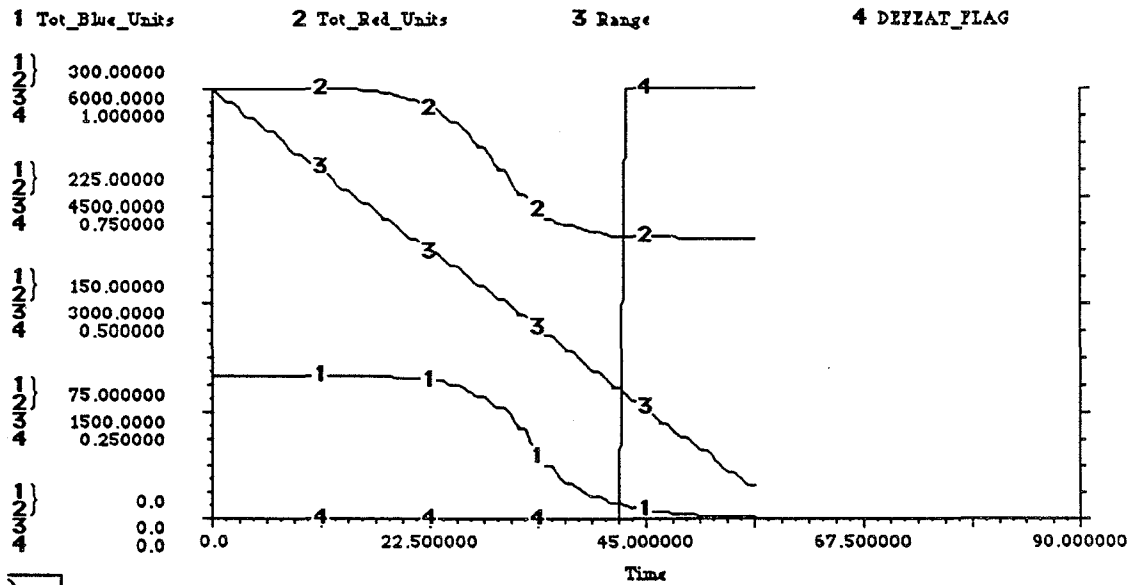

1b

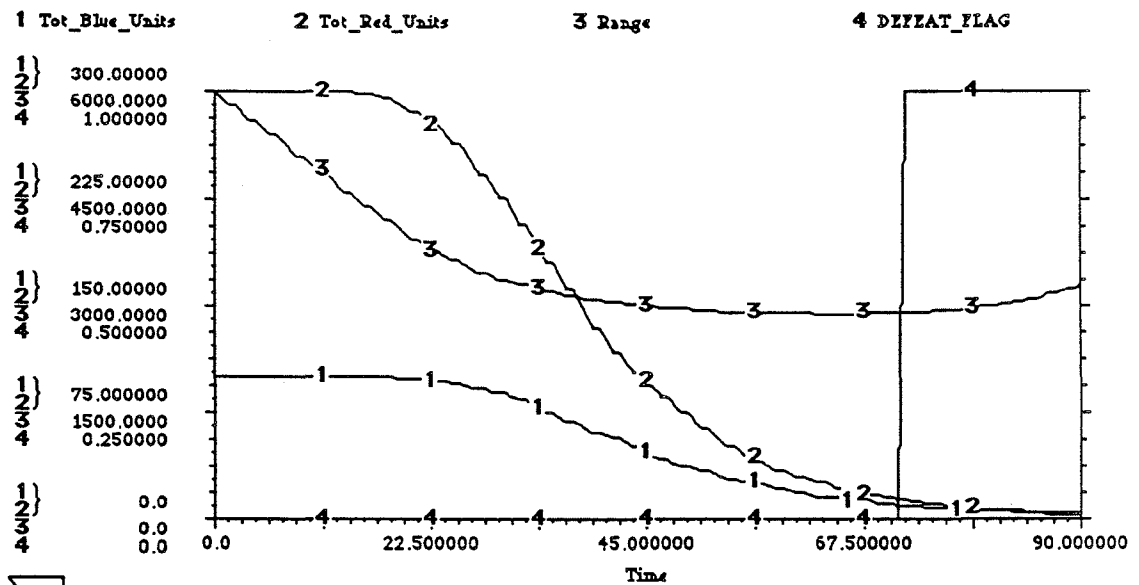

It can be seen in graph 1a that the Blue force is defeated at around time 42, and is annihilated at time 56. During the battle Red maintains a good numerical superiority, and thus advances at a constant maximum speed. It is interesting to note the 'Z' shaped attrition curves of the Red and Blue forces. This arises through the fact that when Red is some distance away from Blue, its weapons are not particularly effective. As the distance between the two forces drops, the weapons become more accurate, and heavy attrition is inflicted. By the time the forces are close together, there are not many units left to kill, so the attrition rate tails off again. If the *proportion* of units which are attrited is plotted, it can be seen to rise in an exponential fashion. It is also interesting to note the effect of removing the Red advance (attrition rates display similar characteristics to those produced by traditional mathematical analysis for the study of static force conflicts). In graph 1b, Blue inflicts heavier attrition on Red, and is able to survive longer (being defeated at time 70, although eventually overturning Red). It can be seen that as the force strength ratio drops in Blue's favour, Red slows his advance and eventually withdraws.

2a

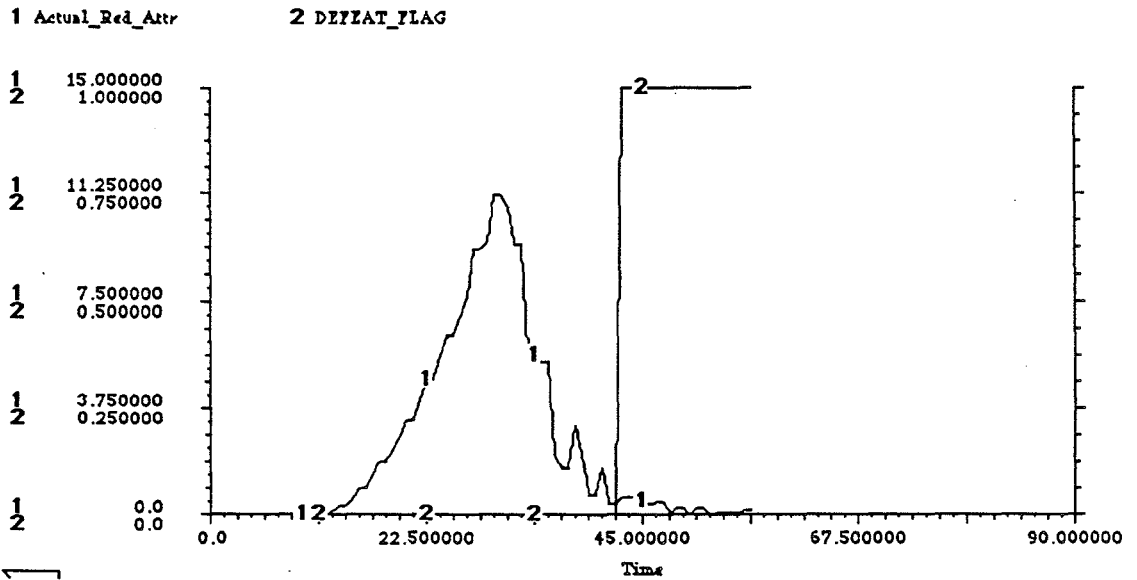

2b

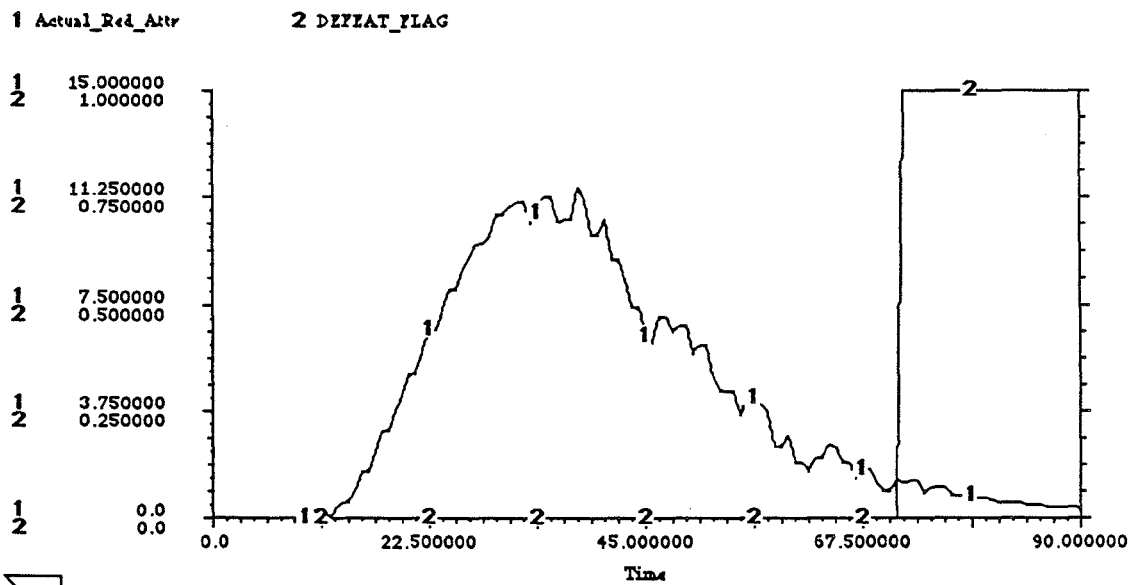

It can be seen in graphs 2a and 2b that the z shape in graphs 1a and b is reflected in the rate of attrition as an attrition 'hump'. Also interesting to note here is the sustained attrition of Red in graph 2b. This tails off because of Red's slowing advance rate, whereas in graph 1a the tail off is caused by Blue's rapid attrition.

3a

1 Blue_No_Obs_Targs

2 DEFEAT_FLAG

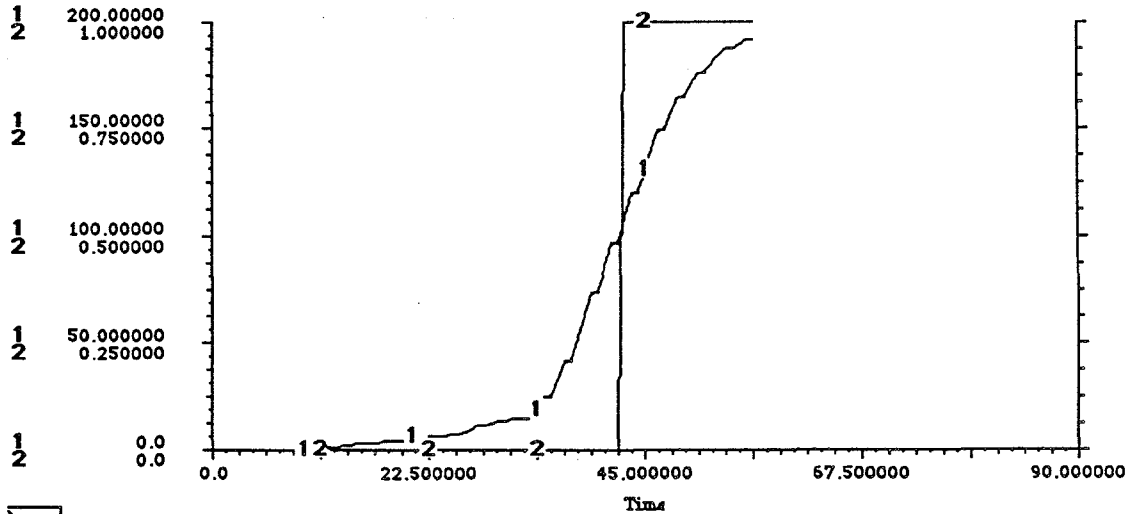

3b

1 Blue_No_Obs_Targs

2 DEFEAT_FLAG

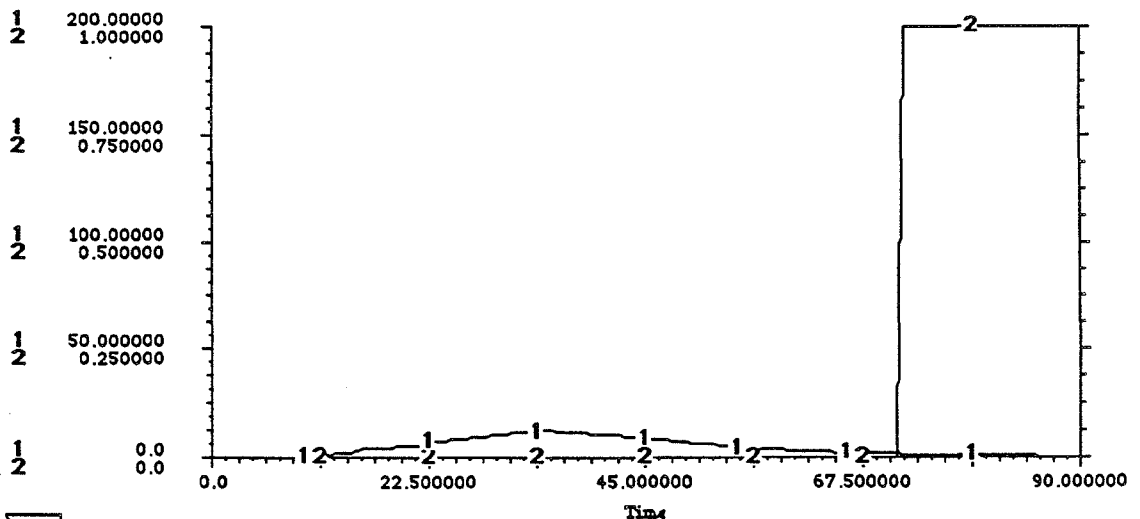

Graphs 3a and 3b show a dramatic effect. 3a shows the number of targets which have been observed but not yet acquired - Blue is aware that the target backlog exists, but has not yet allocated resources to deal with it. As Red advances, the observed backlog increases. However, when Red is close enough to inflict severe attrition on Blue (as can be seen on the turning point of the Blue attrition z-graph in 1a), Blue's stock of units available to acquire Red targets drops dramatically (only one target can be acquired per Blue unit). As Red advances, the number of targets observed by Blue rises sharply, but the ability to acquire still drops with the attrition. Eventually, almost all of the Red targets can be seen (around 200, in graph 3a) but Blue simply does not have any units with which to acquire. This shows a loss of control in the form of a 'ground-rush' effect. In 3b, Blue forces Red to slow down, and also has available more of his own units with which to acquire Red. Thus control is maintained.

4a

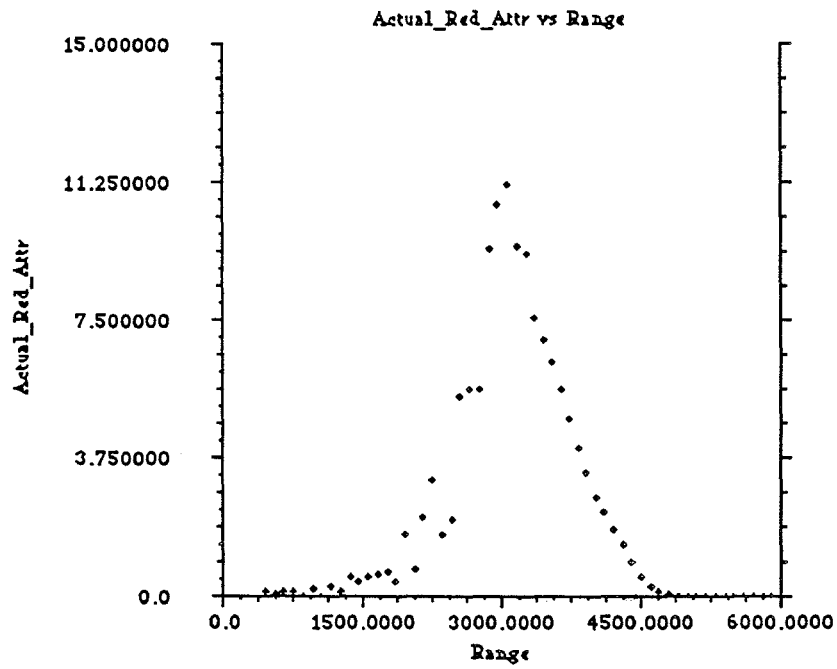

4b

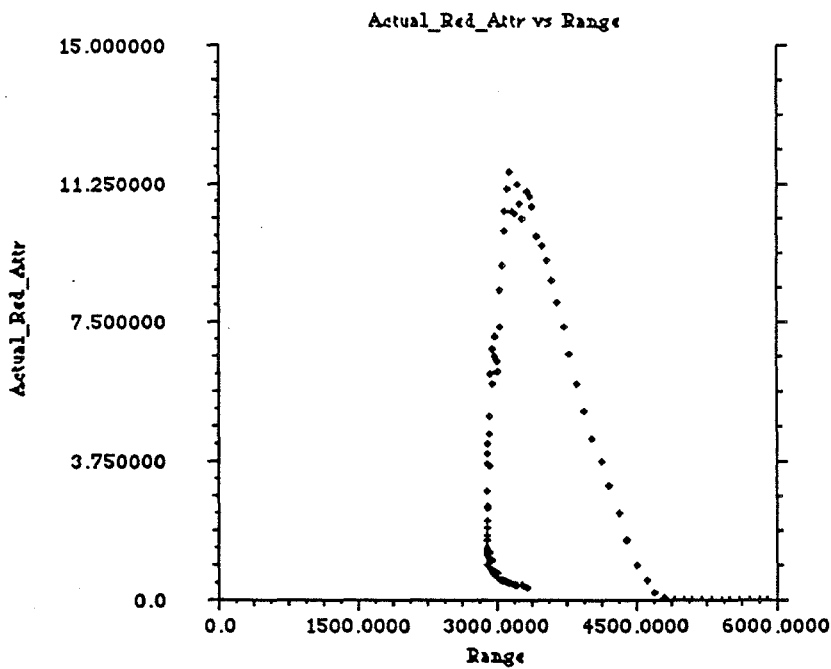

Plots 4a and 4b show the Red attrition against range. It can be seen that the z-graphs shown in 1a and 1b are reflected here, and that the highest rate of Red attrition is actually (and perhaps counter-intuitively) suffered when Red is some distance away from Blue. Remember that Blue suffers heavy attrition in the baseline run and that the force ratio remains in Red's favour. In the CIS run, the ratio tends towards Blue's favour, thus Red slows the advance, eventually withdrawing (seen in graph 4b).

5a

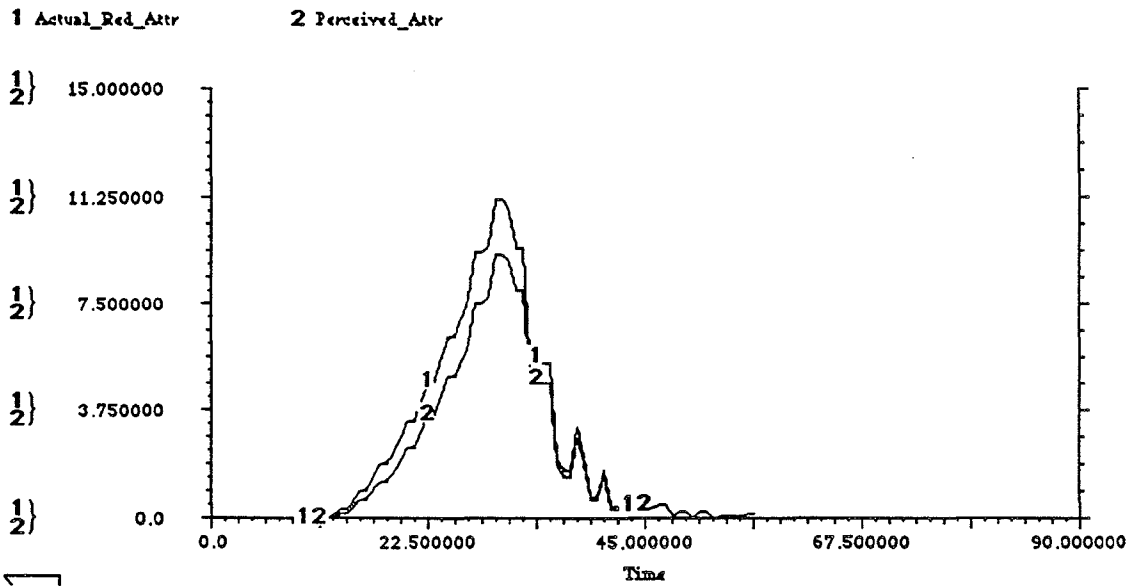

5b

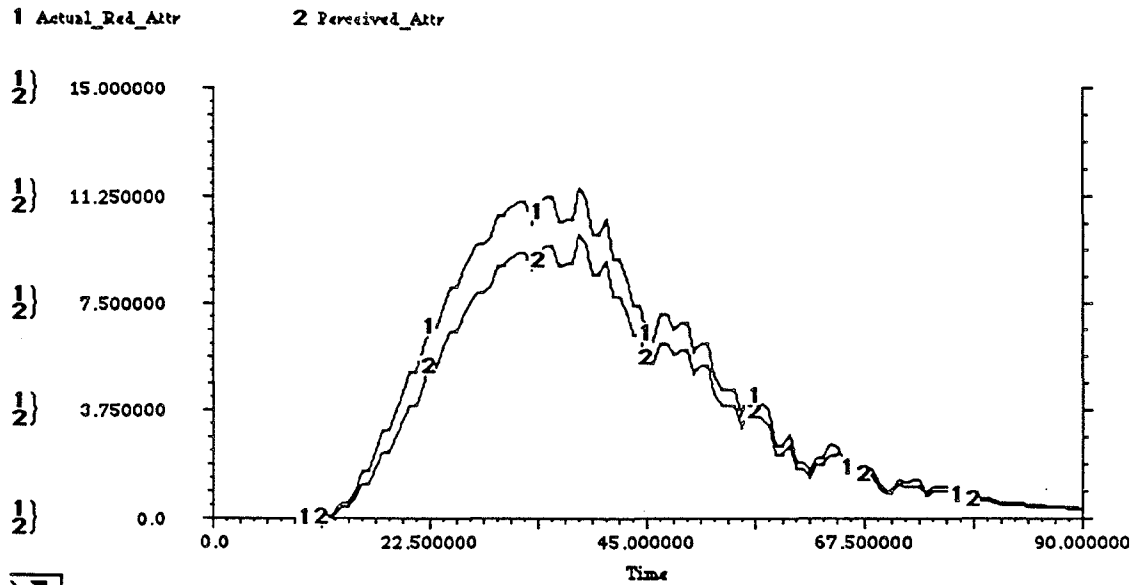

Graphs 5a and b show Blue's perception of Red attrition. The distance between the actual and the perceived plots is effectively an 'overkill space' as it represents the number of killed targets which remain in the acquired state, and must thus be shot again and identified as dead before they can be removed. In graph 5a, it can be seen that this space is reduced over time - i.e. as Red get closer, the accuracy of observation increases. In the CIS run however, the space is not only larger, but it also does not close rapidly. This puzzling effect is explained when it is remembered that in the CIS run Red slows its advance, and therefore remains some distance away from Blue (thereby keeping the observation accuracy the same!) The space eventually closes as the Red attrition approaches zero, thus there is little attrition for Blue to perceive.